



LD300 series

33301-33302-33303

PRESSURE TRANSMITTER

FOR PRESSURE, LEVEL AND FLOW APPLICATIONS

- $\pm 0.04\%$ High Accuracy
- $\pm 0.15\%$ of URL Stability - Guarantee for 12 Years
- 120:1 Rangeability
- Non-volatile Totalizer
- Tank Linearization
- 100 ms Total Response Time
- PID Control Capability
- Bi-directional Flow Measurement
- Advanced Diagnostics
- Largest Library of Function
- Instantiable Function Blocks
- Supported by DD, EDDL and FDT/DTM
- Three Technology Options



smar

- $\pm 0.04\%$ high performance option;
- $\pm 0.15\%$ of URL stability;
- 120:1 rangeability;
- Span as small as 50 Pa (0.2 inH₂O) up to a range limit of 40 MPa (5800 psi);
- Up to 52 MPa static pressure (7500 psi);
- Direct digital capacitance sensing (no A/D conversion);
- True non-interactive zero and span;
- Local zero and span adjustment;
- Remote calibration and parameterization;
- Transfer functions: linear, \sqrt{x} , $\sqrt{x^3}$ e $\sqrt{x^5}$;
- Tank linearization;
- Alphanumeric LCD indication;
- Small and lightweight;
- Explosion proof and weather proof housing approved (IP66/68 or IP66/68W);
- Intrinsically safe certification;
- Signal simulation for loop tests;
- Non-volatile flow totalization;
- Configurable user unit;
- Configurable local adjustment;
- EMC (Electromagnetic Compatibility) according to IEC61326-1:2006, IEC61326-2-3:2006, IEC61000-6-4:2006, IEC61000-6-2:2005;
- Write protection function;
- Three technology options: HART®, FOUNDATION™ fieldbus, PROFIBUS PA.

HART® - 4 to 20 mA

- Update output current in 100 ms with 0.75 μ A resolution;
- Improved performance due to dedicated math co-processor;
- Multidrop operation mode;
- PID control function;
- Supports DTM and EDDL;
- Bi-directional flow measurement;
- With FMEDA analysis and MTBF of 244 years.

FOUNDATION™ fieldbus

- 17 different types of function blocks for control strategies and advanced diagnostics;
- Up to 20 function blocks;
- Execution of up to 29 external links;
- 12 mA consumption;
- Dynamic block instantiation improves interchangeability;
- Fieldbus Foundation™ registered and ITK approved;
- MVC (Multivariable Container) enabled;
- MTBF of 186 years.

PROFIBUS PA

- 12 mA consumption;
- Function blocks for analog input and totalization;
- Integrated to Smar ProfibusView or Simatic PDM;
- Supports DTM and EDDL;
- Profile 3.0 improves interchangeability;
- MTBF of 186 years.



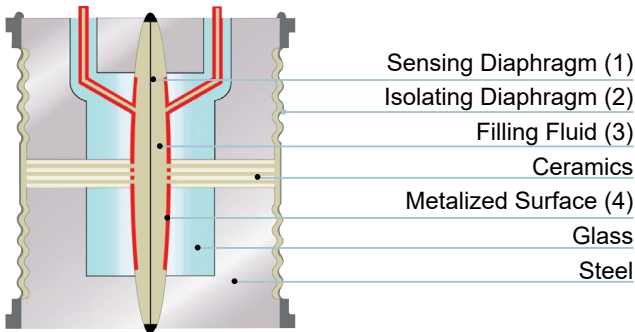

LD300 Series offers:

- ± 0.04% accuracy for high performance option;
- ± 0.15% of URL stability guarantee for 12 Years;
- 120:1 rangeability;
- Compact and lightweight;
- Multiple Protocol Options.

LD300 Series uses the field-proven technique of capacitance cell sensor measurement.

The sensor is shown in the picture above. The sensing diaphragm (1) is at the cell center. The diaphragm deflects as a result of the difference between the pressures applied to the left and right sides of the sensor. Pressure is directly applied to the isolating diaphragms (2), which provide resistance against process fluid corrosion. The pressure is transmitted to the sensing diaphragm through the filling fluid (3).

The sensing diaphragm is a moving capacitor plate while the two metallized surfaces (4) are fixed plates. The sensing diaphragm deflection results in capacitance variations between the moving and fixed plates.

The electronic resonance circuit reads capacitance variation between the moving and fixed plates. The CPU conditions the measurement and communicates according to protocol. As there is no A/D conversion, errors and drifts during conversions are eliminated. A temperature sensor provides temperature compensations, which combined with the sensor precision, results in high accuracy and rangeability for the **LD300 Series**.

The process variable, as well as monitoring and diagnostics information, are provided by digital communication protocol.

The available protocol options are: HART®, FOUNDATION™ fieldbus and PROFIBUS PA.

These protocols are easily changed by either replacing the internal electronic board or downloading the firmware. A HART® transmitter can be changed into a FOUNDATION™ fieldbus / PROFIBUS PA device by replacing the internal card, and vice versa. A FOUNDATION™ fieldbus device can be changed into a PROFIBUS PA device and vice versa, by simply downloading a new firmware.

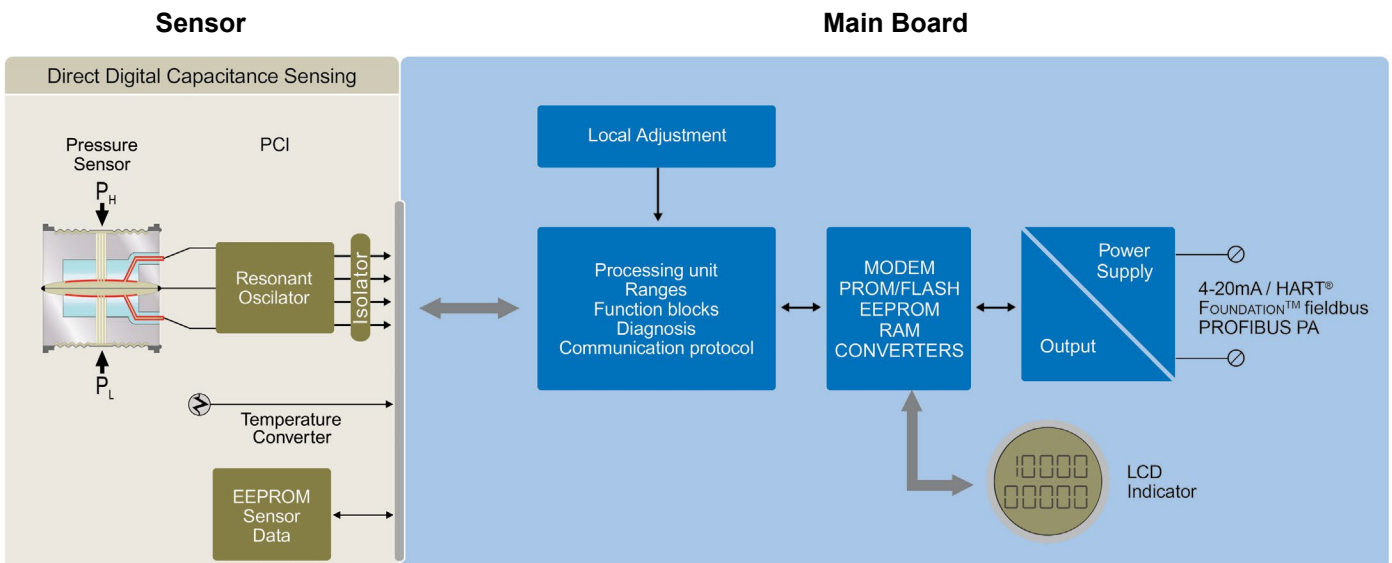

Differential Pressure - LD300D and LD300H

Pressure is applied to high and low sides and differential pressure is measured. High static pressure is supported by **LD300H** models.

Flow - LD300D and LD300H

The differential pressure is generated by a primary flow element and the square root function computes the flow measurement.

Absolute Pressure - LD300A

The pressure is measured at the high side of the transmitter and the low side is at zero absolute reference to a sealed chamber with vacuum.

Gage Pressure - LD300M

The pressure is measured at the high side of the transmitter and the low side is open to the atmosphere, providing true local atmospheric reference.

Level - LD300L

The transmitter has a flange mounted unit for direct installation on vessels. Extended diaphragms are also available. For closed tank low side can compensate for ullage pressure.



Remote Seals

SR301 is a remote seal designed for chemical and thermal isolation. **LD300 Series** can be assembled with separate diaphragm seals in either one or both sides of the sensor. SR301 options include: "T" Type Flanged (SR301T), Threaded (SR301R), Pancake (SR301P) where those three models with an optional flush connection, Sanitary (SR301S), Flanged with Extension (SR301E) and Pancake with Extension (SR301Q). The flush connection enables deposits removal without disconnecting the seal.

Typical applications for **LD300 Series** with remote seals:

- Corrosive process fluid;
- Suspended solids or viscous process fluid;
- Process fluids that may freeze or solidify;
- Process temperatures higher than supported by transmitters;
- Replaces impulse lines and condensate legs;
- Bubble system.

See the Smar SR301 Series catalog for further information regarding application and specification.



Sanitary Transmitter

LD300S Series are specially designed for food and other applications where sanitary connections are required. With threaded or "tri-clamp" connections, it allows for easy and quick maintenance and cleaning. Tri-clamp and other connections are compliant to 3A-7403 standard for food grade applications.

For further information, see the Smar SR301 Series Catalog.



Manifold Valves

Smar manifold valves provide all of the necessary safety for field maintenance of **LD300 Series** transmitters. Working at pressures up to 6,000 psi, they are easy to handle and lighter than others in the market. Pressure and leakage tests carried out in 100% of the valves, also for models mounted on the transmitter. For further information, please see the Smar Manifold Valves Catalog.



LD300 Series are available in three different technologies: HART® (**LD301**), FOUNDATION™ fieldbus (**LD302**) and PROFIBUS PA (**LD303**).

These instruments can be configured with Smar software and other manufacturers' configuration tools. Local adjustment is available in all **LD300 Series**. It is possible to configure zero and span, totalization, set point and other control functions using the magnetic screwdriver.

Smar has developed AssetView, which is a user-friendly Web Tool that can be accessed anywhere and anytime using an Internet browser. It is designed for management and diagnostics of field devices to ensure reactive, preventive, predictive and proactive maintenance.



HART® - LD301

LD301 (HART® protocol) can be configured by:

- Smar CONF401 for Windows;
- Smar DDCON100 for Windows;
- Smar HPC301 and HPC401 for several models of Palm;
- Other manufacturers' configuration tools based on DD (Device Description) or DTM (Device Type Manager), such as AMS™, FieldCare™, PACTware™, HHT275 and HHT375, PRM Device Viewer.

For **LD301** management and diagnostics, AssetView ensures continuous information monitoring.



Universal HART® Configuration Software



HPC401

FOUNDATION™ fieldbus - LD302

LD302 utilizes the FOUNDATION™ fieldbus H1 protocol, an open technology that allows any H1 enabled configuration tool to configure this device.

Sycon302 (System Configuration Tool) is a software tool used to configure, maintain and operate the field devices. Sycon offers efficient and friendly interaction with the user, using Windows.

Configuration tools such as AMS™, FieldCare™ and HHT375 can configure **LD302** devices. DD (Device Description) and CF (Capability File) files can be downloaded at either the Smar or Fieldbus Foundation™ website.

LD302 supports complex strategies configurations due to the high capacity and variety of dynamic instantiable function blocks.

Seventeen different types of function blocks are supported, and up to 20 function blocks can be running simultaneously.

Maintenance procedures with AssetView diagnostics and status information from FOUNDATION™ fieldbus result in a safer plant with higher availability.

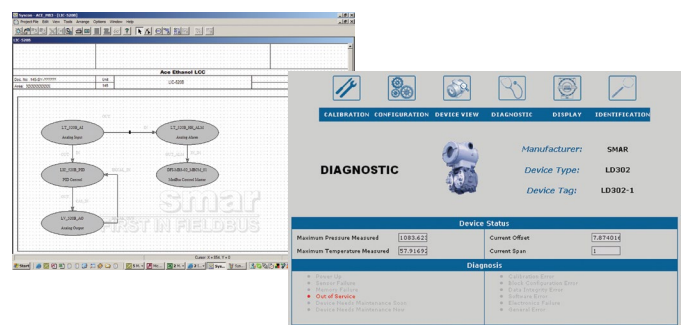

PROFIBUS PA - LD303

LD303 (PROFIBUS PA protocol) can be configured using Smar ProfibusView or Simatic PDM and by the FDT (Field Device Tool) and DTM (Device Type Manager) concept tools, such as FieldCare™ and PACTware™. It can also be integrated by any PROFIBUS System using the GSD file.

PROFIBUS PA also has quality and diagnostic information, improving plant management and maintenance. Conforms to profile 3.0.

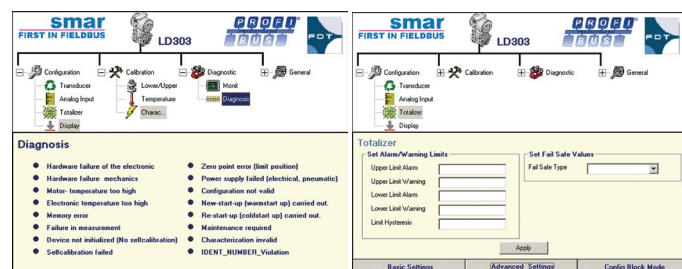

HART® - LD301

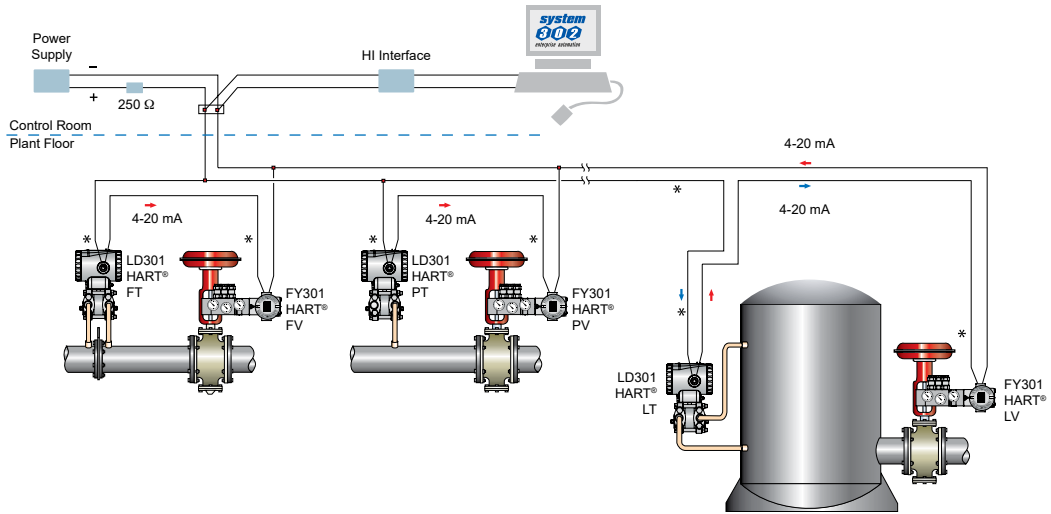

FOUNDATION™ fieldbus - LD302

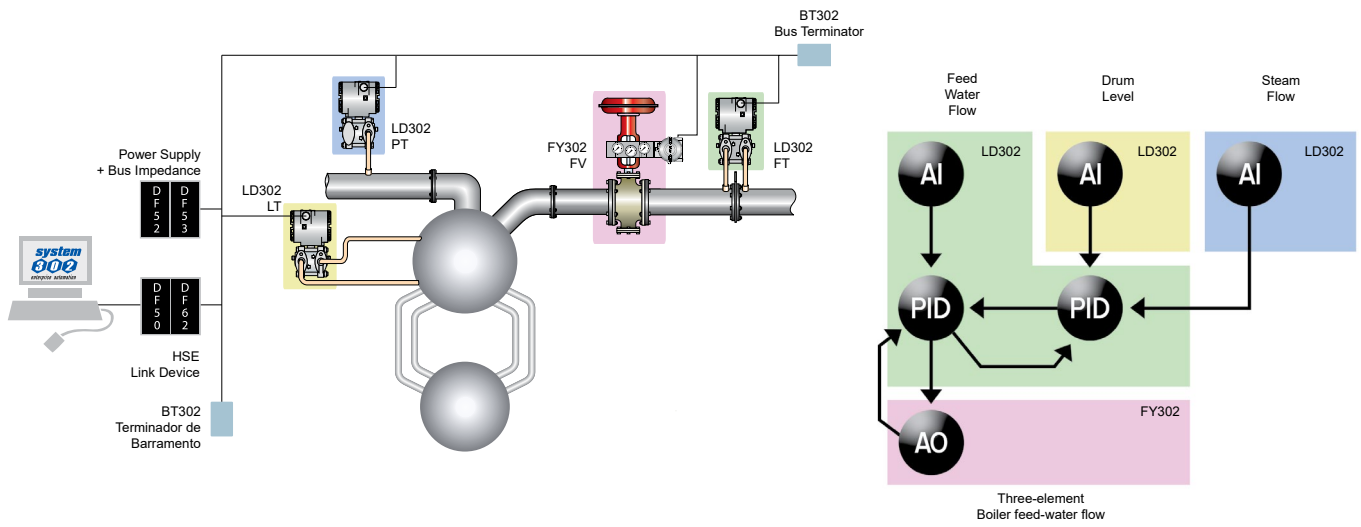

PROFIBUS PA- LD303

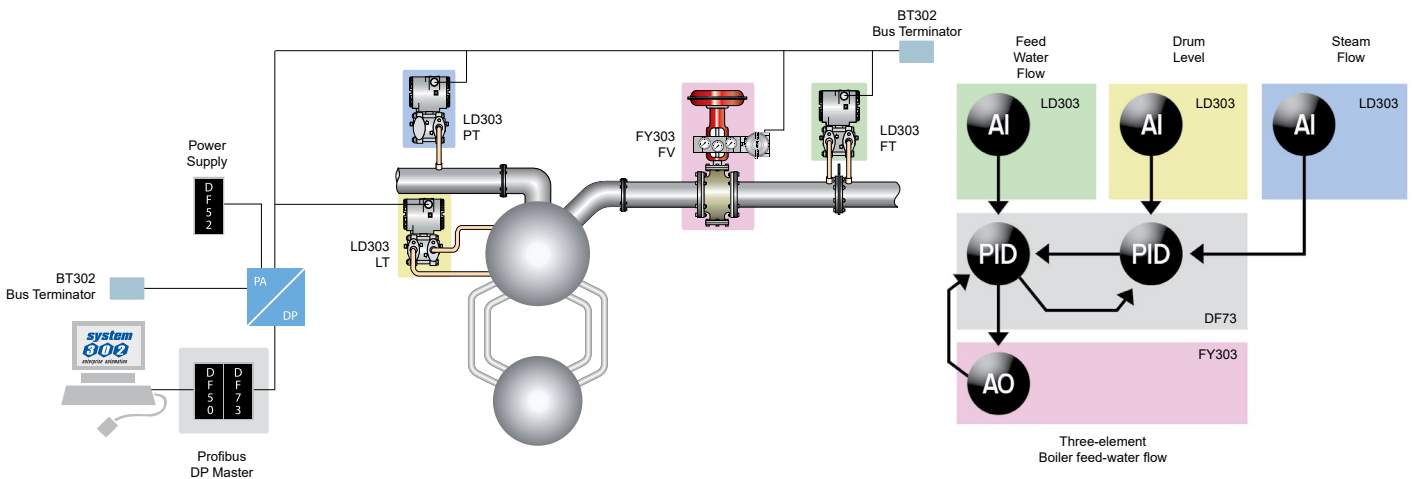

Functional Specifications

Process Fluid	Liquid, gas or steam.
Output and Communication Protocol	<p>HART®: Two-wire, 4-20 mA according to NAMUR NE43 specification, with superimposed digital communication (HART® Protocol).</p> <p>FOUNDATION™ fieldbus and PROFIBUS PA: Digital only. Complies with IEC 61158-2:2000 (H1): 31.25 kbit/s voltage mode, bus powered.</p>
Power Supply / Current Consumption	<p>HART®: 12 to 45 Vdc.</p> <p>Transient Suppressor Vmax = 65 Vp; Differential mode - bi-directional; Low current leak and capacitance; meets the standards: IEEE61000-4-4 and IEEE61000-4-5; Less than 5 ns response time.</p> <p>FOUNDATION™ fieldbus and PROFIBUS PA: Bus powered: 9 to 32 Vdc. Quiescent current consumption: 12 mA.</p>
Indicator	4½-digit numerical and 5-character alphanumeric LCD indicator (optional).
Hazardous Area Certifications	<p>HART®, FOUNDATION™ fieldbus and PROFIBUS PA: Intrinsically Safe (FM, CSA, NEMKO, EXAM, CEPEL, NEPSI), explosion proof (FM, CSA, NEMKO, CEPEL, NEPSI), dust ignition proof (FM) and non-incendive (FM).</p> <p>FOUNDATION™ fieldbus and PROFIBUS PA: FISCO Field Device Ex ia IIC T4 FNICO Field Device Ex n1 IIC T4</p>
European Directive Information	<p>Authorized representative in European Community Smar GmbH-Rheingaustrasse 9-55545 Bad Kreuznach</p> <p>PED Directive (97/23/EC) - Pressure Equipment Directive This product is in compliance with the directive and it was designed and manufactured in accordance with sound engineering practice using several standards from ANSI, ASTM, DIN and JIS.</p> <p>EMC Directive (2004/108/EC) - Eletromagnetic Compatibility The EMC test was performed according to IEC standard: IEC61326-1:2006, IEC61326-2-3:2006, IEC61000-6-4:2006, IEC61000-6-2:2005. For use in environment only. Keep the shield insulated at the instrument side, connecting the other one to the ground if necessary to use shielded cable.</p> <p>ATEX Directive (94/9/EC) - Equipment and protective systems intended for use in potentially explosive atmospheres This product was certified according European Standards at NEMKO and EXAM (old DMT). The certified body for manufacturing quality assessment is EXAM (number 0158).</p> <p>LVD Directive 2006/95/EC - Electrical Equipment designed for use within certain voltage limits According the LVD directive Annex II the equipment under ATEX “Electrical equipment for use in an explosive atmosphere” directive are excluded from scope from this directive. The EC declarations of conformity for all applicable European directives for this product can be found at www.smar.com.</p>
Zero and Span Adjustments	Noninteractive, via digital communication or local adjustment.
Failure Alarm (Diagnostics)	<p>Detailed diagnostics through communication for all protocols.</p> <p>HART®: In case of sensor or circuit failure, the self diagnostics drives the output to 3.6 or 21.0 mA, according to the user’s choice and NAMUR NE43 specification.</p> <p>FOUNDATION™ fieldbus and PROFIBUS PA: For sensor circuit failures, events are generated and status is sent to link outputs. Detailed diagnostics are available in the contained parameters.</p>

<p>Temperature Limits</p>	<p>Ambient: -40 a 85 °C (-40 a 185 °F) Process: -40 a 100 °C (-40 a 212 °F) (Silicone Oil) -40 a 85 °C (-40 a 185 °F) (Inert Halocarbon Oil) 0 a 85 °C (32 a 185 °F) (Inert Fluorolube Oil) -20 a 85 °C (-4 a 185 °F) (Inert Krytox Oil and Fomblim Oil) -25 a 100 °C (-13 a 212 °F) (Viton O'Ring) -40 a 150 °C (-40 a 302 °F) (LD301L) Storage: -40 a 100 °C (-40 a 212 °F) Digital Display: -20 a 80 °C (-4 a 176 °F) -40 a 85 °C (-40 a 185 °F) (without damage)</p>																																																																																
<p>Turn-on Time</p>	<p>HART®: Performs within specifications in less than 5 seconds after power is applied to the transmitter. FOUNDATION™ fieldbus and PROFIBUS PA: Performs within specifications in less than 10 seconds after power is applied to the transmitter.</p>																																																																																
<p>Configuration</p>	<p>HART®: By digital communication (HART® protocol) using the configuration software CONF401, DDCON100 (for windows), HPC301 or HPC401 (for Palm). It can also be configured using DD and FDT/DTM tools, and can be partially configured through local adjustment. FOUNDATION™ fieldbus and PROFIBUS PA: Basic configuration may be done using the local adjustment magnetic tool if device is fitted with display. Complete configuration is possible using configuration tools.</p>																																																																																
<p>Volumetric Displacement</p>	<p>Less than 0.15 cm³ (0.01 in³)</p>																																																																																
<p>Overpressure and Static Pressure Limits (MWP – Maximum Working Pressure)</p>	<p>From 3.45 kPa abs. (0.5 psia)* to: 4600 psi (320 bar) for models H2 and H5 70 psi (5 bar) for range 0 5800 psi (400 bar) for range 5 1200 psi (80 bar) for range 1 7500 psi (520 bar) for range 6 2300 psi (160 bar) for ranges 2, 3 and 4 * <i>except the LD301A model</i></p> <p>Flange Test Pressure (Burst Pressure): 68.95 MPa (10,000 psi)</p> <p>C63 certificate is available under request, for 480 bar static pressure and 380 bar overpressure. For classified areas, it must be observed maximum operation pressure according to the Explosion Proof Certificate according to the area.</p> <p>Overpressures above will not damage the transmitter, but a new calibration may be necessary.</p> <div style="border: 1px solid black; padding: 5px; margin: 10px 0;"> <p style="text-align: center;">WARNING</p> <p>It is described here only the maximum pressures of the materials referenced in each rule, it can not be manufactured on request.</p> <p>Temperatures above 150 °C are not available in standard models.</p> </div> <p style="text-align: center;">PRESSURES TABLE FOR SEAL AND LEVEL FLANGES DIN EN 1092-1 2008 STANDARD</p> <table border="1" style="width: 100%; border-collapse: collapse; text-align: center;"> <thead> <tr> <th rowspan="3" style="width: 15%;">Material Group</th> <th rowspan="3" style="width: 10%;">Pressure Class</th> <th colspan="7" style="background-color: #0070C0; color: white;">Maximum Temperature Allowed</th> </tr> <tr> <th style="width: 5%;">RT</th> <th style="width: 5%;">100</th> <th style="width: 5%;">150</th> <th style="width: 5%;">200</th> <th style="width: 5%;">250</th> <th style="width: 5%;">300</th> <th style="width: 5%;">350</th> </tr> <tr> <th colspan="7" style="background-color: #0070C0; color: white;">Maximum Pressure Allowed (bar)</th> </tr> </thead> <tbody> <tr> <td rowspan="7" style="text-align: left; vertical-align: middle;">10E0 AISI 304/304L</td> <td>PN 16</td> <td>16</td> <td>13.7</td> <td>12.3</td> <td>11.2</td> <td>10.4</td> <td>9,6</td> <td>9.2</td> </tr> <tr> <td>PN 25</td> <td>25</td> <td>21.5</td> <td>19.2</td> <td>17.5</td> <td>16.3</td> <td>15.1</td> <td>14.4</td> </tr> <tr> <td>PN 40</td> <td>40</td> <td>34.4</td> <td>30.8</td> <td>28</td> <td>26</td> <td>24.1</td> <td>23</td> </tr> <tr> <td>PN 63</td> <td>63</td> <td>63</td> <td>57.3</td> <td>53.1</td> <td>50.1</td> <td>46.8</td> <td>45</td> </tr> <tr> <td>PN 100</td> <td>100</td> <td>86.1</td> <td>77.1</td> <td>70</td> <td>65.2</td> <td>60.4</td> <td>57.6</td> </tr> <tr> <td>PN 160</td> <td>160</td> <td>137.9</td> <td>123.4</td> <td>112</td> <td>104.3</td> <td>96.7</td> <td>92.1</td> </tr> <tr> <td>PN 250</td> <td>250</td> <td>215.4</td> <td>192.8</td> <td>175</td> <td>163</td> <td>151.1</td> <td>144</td> </tr> </tbody> </table>	Material Group	Pressure Class	Maximum Temperature Allowed							RT	100	150	200	250	300	350	Maximum Pressure Allowed (bar)							10E0 AISI 304/304L	PN 16	16	13.7	12.3	11.2	10.4	9,6	9.2	PN 25	25	21.5	19.2	17.5	16.3	15.1	14.4	PN 40	40	34.4	30.8	28	26	24.1	23	PN 63	63	63	57.3	53.1	50.1	46.8	45	PN 100	100	86.1	77.1	70	65.2	60.4	57.6	PN 160	160	137.9	123.4	112	104.3	96.7	92.1	PN 250	250	215.4	192.8	175	163	151.1	144
Material Group	Pressure Class			Maximum Temperature Allowed																																																																													
				RT	100	150	200	250	300	350																																																																							
		Maximum Pressure Allowed (bar)																																																																															
10E0 AISI 304/304L	PN 16	16	13.7	12.3	11.2	10.4	9,6	9.2																																																																									
	PN 25	25	21.5	19.2	17.5	16.3	15.1	14.4																																																																									
	PN 40	40	34.4	30.8	28	26	24.1	23																																																																									
	PN 63	63	63	57.3	53.1	50.1	46.8	45																																																																									
	PN 100	100	86.1	77.1	70	65.2	60.4	57.6																																																																									
	PN 160	160	137.9	123.4	112	104.3	96.7	92.1																																																																									
	PN 250	250	215.4	192.8	175	163	151.1	144																																																																									

Overpressure and Static Pressure Limits (MWP - Maximum Working Pressure) (continuation)

Material Group	Pressure Class	Maximum Temperature Allowed						
		RT	100	150	200	250	300	350
		Maximum Pressure Allowed (bar)						
14E0 AISI 316/316L	PN 16	16	16	14.5	13.4	12.7	11.8	11.4
	PN 25	25	25	22.7	21	19.8	18.5	17.8
	PN 40	40	40	36.3	33.7	31.8	29.7	28.5
	PN 63	63	63	57.3	53.1	50.1	46.8	45
	PN 100	100	100	90.9	84.2	79.5	74.2	71.4
	PN 160	160	160	145.5	134.8	127.2	118.8	114.2
	PN 250	250	250	227.3	210.7	198.8	185.7	178.5

Material Group	Pressure Class	Maximum Temperature Allowed						
		RT	100	150	200	250	300	350
		Maximum Pressure Allowed (bar)						
16E0 1.4410 Super Duplex 1.4462 Duplex	PN 16	16	16	16	16	16	-	-
	PN 25	25	25	25	25	25	-	-
	PN 40	40	40	40	40	40	-	-
	PN 63	63	63	63	63	63	-	-
	PN 100	100	100	100	100	100	-	-
	PN 160	160	160	160	160	160	-	-
	PN 250	250	250	250	250	250	-	-

PRESSURES TABLE FOR SEAL AND LEVEL FLANGES ASME B16.5 2009 STANDARD

Material Group	Pressure Class	Maximum Temperature Allowed								
		-29 to 38	50	100	150	200	250	300	325	350
		Maximum Pressure Allowed (bar)								
Hastelloy C276	150	20	19.5	17.7	15.8	13.8	12.1	10.2	9.3	8.4
	300	51.7	51.7	51.5	50.3	48.3	46.3	42.9	41.4	40.3
	400	68.9	68.9	68.7	66.8	64.5	61.7	57	55	53.6
	600	103.4	103.4	103	100.3	96.7	92.7	85.7	82.6	80.4
	900	155.1	155.1	154.6	150.6	145	139	128.6	124	120.7
	1500	258.6	258.6	257.6	250.8	241.7	231.8	214.4	206.6	201.1
	2500	430.9	430.9	429.4	418.2	402.8	386.2	357.1	344.3	335.3

Material Group	Pressure Class	Maximum Temperature Allowed								
		-29 to 38	50	100	150	200	250	300	325	350
		Maximum Pressure Allowed (bar)								
S31803 Duplex S32750 Super Duplex	150	20	19.5	17.7	15.8	13.8	12.1	10.2	9.3	8.4
	300	51.7	51.7	50.7	45.9	42.7	40.5	38.9	38.2	37.6
	400	68.9	68.9	67.5	61.2	56.9	53.9	51.8	50.9	50.2
	600	103.4	103.4	101.3	91.9	85.3	80.9	77.7	76.3	75.3
	900	155.1	155.1	152	137.8	128	121.4	116.6	114.5	112.9
	1500	258.6	258.6	253.3	229.6	213.3	202.3	194.3	190.8	188.2
	2500	430.9	430.9	422.2	382.7	355.4	337.2	323.8	318	313.7

Overpressure and Static Pressure Limits (MWP - Maximum Working Pressure) (continuation)	Material Group	Pressure Class	Maximum Temperature Allowed								
			-29 to 38	50	100	150	200	250	300	325	350
	Material Group	Pressure Class	Maximum Pressure Allowed (bar)								
			-29 to 38	50	100	150	200	250	300	325	350
	AISI316L	150	15.9	15.3	13.3	12	11.2	10.5	10	9.3	8.4
		300	41.4	40	34.8	31.4	29.2	27.5	26.1	25.5	25.1
		400	55.2	53.4	46.4	41.9	38.9	36.6	34.8	34	33.4
		600	82.7	80	69.6	62.8	58.3	54.9	52.1	51	50.1
		900	124.1	120.1	104.4	94.2	87.5	82.4	78.2	76.4	75.2
		1500	206.8	200.1	173.9	157	145.8	137.3	130.3	127.4	125.4
		2500	344.7	333.5	289.9	261.6	243	228.9	217.2	212.3	208.9
	Material Group	Pressure Class	Maximum Temperature Allowed								
			-29 to 38	50	100	150	200	250	300	325	350
	Material Group	Pressure Class	Maximum Pressure Allowed (bar)								
			-29 to 38	50	100	150	200	250	300	325	350
	AISI316	150	19	18.4	16.2	14.8	13.7	12.1	10.2	9.3	8.4
		300	49.6	48.1	42.2	38.5	35.7	33.4	31.6	30.9	30.3
		400	66.2	64.2	56.3	51.3	47.6	44.5	42.2	41.2	40.4
		600	99.3	96.2	84.4	77	71.3	66.8	63.2	61.8	60.7
		900	148.9	144.3	126.6	115.5	107	100.1	94.9	92.7	91
		1500	248.2	240.6	211	192.5	178.3	166.9	158.1	154.4	151.6
2500		413.7	400.9	351.6	320.8	297.2	278.1	263.5	257.4	252.7	
Material Group	Pressure Class	Maximum Temperature Allowed									
		-29 to 38	50	100	150	200	250	300	325	350	
Material Group	Pressure Class	Maximum Pressure Allowed (bar)									
		-29 to 38	50	100	150	200	250	300	325	350	
AISI304	150	19	18.3	15.7	14.2	13.2	12.1	10.2	9.3	8.4	
	300	49.6	47.8	40.9	37	34.5	32.5	30.9	30.2	29.6	
	600	99.3	95.6	81.7	74	69	65	61.8	60.4	59.3	
	1500	248.2	239.1	204.3	185	172.4	162.4	154.6	151.1	148.1	
	2500	413.7	398.5	340.4	308.4	287.3	270.7	257.6	251.9	246.9	
Humidity Limits	0 to 100% RH (Relative Humidity)										
Damping Adjustment	User configurable from 0 to 128 seconds (via digital communication).										

Performance Specifications

Reference Conditions	Span starting at zero, temperature of 25 °C (77 °F), atmospheric pressure, power supply of 24 Vdc, fill fluid in Silicone Oil, O’Ring in Buna-N, isolating diaphragms in 316L SST and digital trim equal to lower and upper range values.
Accuracy	<p>For range 0, and differential or gage models and 316L SST or hastelloy diaphragm with silicon or halocarbon filling fluid:</p> <p>0.2 URL ≤ span ≤ URL: ± 0.1% of span</p> <p>0.05 URL ≤ span < 0.2 URL: ± [0.025+0.015 URL/span]% of span</p> <p>For ranges 1, 2, 3, 4, 5 or 6, differential or gage models, and 316L SST or hastelloy diaphragm with silicon or halocarbon filling fluid:</p> <p>0.1 URL ≤ span ≤ URL: ± 0.075% of span</p> <p>0.025 URL ≤ span < 0.1 URL: ± [0.0375+0.00375.URL/span]% of span</p> <p>0.0083 URL ≤ span < 0.025 URL: ± [0.0015+0.00465.URL/span]% of span</p>

<p>Accuracy (continuation)</p>	<p>For ranges 2 to 6 and absolute model. For tantalum or monel diaphragm. For fluorolube filling fluid: 0.1 URL ≤ span ≤ URL: ± 0.1% of span 0.025 URL ≤ span < 0.1 URL: ± 0.05[1+0.1 URL/span]% of span 0.0083 URL ≤ span < 0.025 URL: ± [0.01+0.006 URL/span]% of span</p> <p>For range 1 and absolute model: ± 0.2% of span</p> <p>For ranges 2, 3 or 4 and level model and 316L SST diaphragm with silicon or halocarbon filling fluid with maximum pressure matching the flange pressure class: 0.1 URL ≤ span ≤ URL: ± 0.075% of span 0.025 URL ≤ span < 0.1 URL: ± [0.0375+0.00375.URL/span]% of span 0.0083 URL ≤ span < 0.025 URL: ± [0.0015+0.00465.URL/span]% of span</p> <p>Linearity effects, hysteresis and repeatability are included.</p>
<p>Stability</p>	<p>For ranges 2, 3, 4, 5 and 6: ± 0.15% of URL for 5 years at 20 °C temperature change and up to 7 MPa (1000 psi) of static pressure For ranges 0 and 1: ± 0.2% of URL for 12 months at 20 °C temperature change and up to 100 kPa (1 bar) of static pressure For Level transmitters: ± 0.2% of URL for 12 months at 20 °C temperature change</p>
<p>Temperature Effect</p>	<p>For ranges 2, 3, 4, 5 and 6: 0.2 URL ≤ span ≤ URL: ± [0.02% URL + 0.06% span] per 20 °C (68 °F) 0.0085 URL ≤ span < 0.2 URL: ± [0.023% URL + 0.045% span] per 20 °C (68 °F)</p> <p>For range 1: 0.2 URL ≤ span ≤ URL: ± [0.08% URL + 0.05% span] per 20 °C (68 °F) 0.025 URL ≤ span < 0.2 URL: ± [0.06% URL + 0.15% span] per 20 °C (68 °F)</p> <p>For range 0: 0.2 URL ≤ span ≤ URL: ± [0.15% URL + 0.05% span] per 20 °C (68 °F) 0.05 URL ≤ span < 0.2 URL: ± [0.1% URL + 0.3% span] per 20 °C (68 °F)</p> <p>For LD300L: 6 mmH₂O per 20 °C for 4" and DN100 17 mmH₂O per 20 °C for 3" and DN80 Consult for other flange dimensions and fill fluid.</p>
<p>Static Pressure Effect</p>	<p>Zero error: For ranges 2, 3, 4, 5 and 6: ± 0.033% URL per 7 MPa (1000 psi) For range 1: ± 0.05% URL per 1.7 MPa (250 psi) For range 0: ± 0.1% URL per 0.5 MPa (5 bar) For Level transmitters: ± 0.1% URL per 3.5 MPa (500 psi)</p> <p>The zero error is a systematic error that can be eliminated by calibrating at the operating static pressure.</p> <p>Span error: For ranges 2, 3, 4, 5 and 6: correctable to ± 0.2% of reading per 7 MPa (1000 psi) For range 1 and level transmitters: correctable to ± 0.2% of reading per 3.5 MPa (500 psi) For range 0: correctable to ± 0.2% of reading per 0.5 MPa (5 bar)</p>
<p>Power Supply Effect</p>	<p>± 0.005% of calibrated span per volt.</p>
<p>Mounting Position Effect</p>	<p>Zero shift of up to 250 Pa (1 inH₂O) which can be calibrated out. No span effect.</p>
<p>Electromagnetic Interference Effect</p>	<p>Approved according to IEC61326-1:2006, IEC61326-2-3:2006, IEC61000-6-4:2006, IEC61000-6-2:2005.</p>

Physical Specifications

Electrical Connection	<p>½ - 14 NPT M20 X 1.5 PG 13.5 DIN</p> <p>¾ - 14 NPT (with 316 SST adapter for 1/2 - 14 NPT) ¾ - 14 BSP (with 316 SST adapter for 1/2 - 14 NPT) ½ - 14 BSP (with 316 SST adapter for 1/2 - 14 NPT)</p>
Process Connection	<p>¼ - 18 NPT or ½ - 14 NPT (with adapter). For L models see Ordering Code. See Ordering Code for more options.</p>
Wetted Parts	<p>Isolating Diaphragms: 316L SST, Hastelloy C276, Monel 400 or Tantalum.</p> <p>Drain/Vent Valves and Plug: 316 SST, Hastelloy C276 or Monel 400.</p> <p>Flanges: Plated Carbon Steel, 316 SST CF8M (ASTM - A351), Hastelloy C276 - CW-12MW, (ASTM - A494) or Monel 400.</p> <p>Wetted O-Rings (For Flanges and Adapters): Buna-N, Viton™, PTFE or Ethylene-Propylene. The LD300 is available in NACE MR-01-75/ISO 15156 compliant materials.</p>
Nonwetted Parts	<p>Electronic Housing: Injected aluminum with polyester painting, epoxy painting or 316 SST - CF8M (ASTM - A351) housing. Complies with NEMA 4X/6P, IP66 ou IP66W*, IP68 ou IP68W*.</p> <p>Note: *The IP66/68W sealing test (immersion) was performed at 1 bar for 24 hours. For any other situation, please consult Smar. IP66/68W tested for 200h to according NBR 8094 / ASTM B 117 standard.</p> <p>Blank Flange: When flange adapter and Drain/Vent material is Carbon Steel, blank flange is in Carbon Steel, otherwise blank flange is in 316 SST CF8M (ASTM - A351).</p> <p>Level Flange (LD300L): 316L SST, 304 SST, Hastelloy C276 and Plated Carbon Steel.</p> <p>Fill Fluid: Silicone, Fluorolube, Krytox, Halocarbon 4.2 or Fomblim oils.</p> <p>Cover O'Ring: Buna-N</p> <p>Mounting Bracket: Plated Carbon Steel or 316 SST. Accessories (bolts, nuts, washers and U-clamps) in Carbon Steel or 316 SST.</p> <p>Flange Bolts and Nuts: Plated Carbon Steel, Grade 8 or 316 SST. For NACE applications: Carbon Steel ASTM A193 B7M.</p> <p>Identification Plate: 316 SST.</p>
Mounting	<p>a) Flange mounted for Level models. b) Optional universal mounting bracket for surface or vertical/horizontal 2"-pipe (DN 50). c) Manifold Valve integrated to the transmitter. d) Directly on piping for closely coupled transmitter/orifice flange combinations.</p>
Approximate Weights	<p>3.15 kg (7 lb): all models, except L models. 5.85 to 9.0 kg (13 lb to 20 lb): L models depending on the flanges, extension and materials.</p>
Control Functions Characteristics (Optional)	<p>HART® PID Control (PID) and Totalizer (TOT)</p> <p>FOUNDATION™ fieldbus Resource (RS), Transducer (TRD), Diagnostics Transducer Block (DIAG), Analog Input (AI), PID Control (PID), Advanced PID Control (APID), Arithmetic (ARTH), Integrator (INTG), Input Selector (ISEL), Signal Characterizer (CHAR), Analog Alarm (AALM), Timer and Logic (TIME), Lead Lag (LLAG), Output Signal Selector and Dynamic Limiter (OSDL), Constant (CT) and Density (DENS).</p> <p>PROFIBUS PA Physical Block (PHY), Transducer (TRD), Analog Input (AI) and Totalizer (TOT)</p>

High Performance option (code L1) is available under the following conditions only:

Application	Differential Gage								
Range	D0	-1	1	0.05	kPa	-4	4	0.2	inH ₂ O
	D1	-5	5	0.10	kPa	-20	20	0.4	inH ₂ O
	D2	-50	50	0.42	kPa	-200	200	1.67	inH ₂ O
	D3	-250	250	2.08	kPa	-36	36	0.3	psi
	D4	-2500	2500	20.83	kPa	-360	360	3	psi
	M0	-1	1	0.05	kPa	-4	4	0.2	inH ₂ O
	M1	-5	5	0.10	kPa	-20	20	0.4	inH ₂ O
	M2	-50	50	0.42	kPa	-200	200	1.67	inH ₂ O
	M3	-100	250	2.08	kPa	-14.50	36	0.3	psi
	M4	-100	2500	20.83	kPa	-14.50	360	3	psi
	M5	-0.1	25	0.21	MPa	-14.50	3600	30	psi
	M6	-0.1	40	0.33	MPa	-14.50	5800	48.3	psi
	H2	-50	50	0.42	kPa	-200	200	1.67	inH ₂ O
	H3	-250	250	2.08	kPa	-36	36	0.3	psi
	H4	-2500	2500	20.83	kPa	-360	360	3	psi
H5	-25	25	0.21	MPa	-3600	3600	30	psi	
Diaphragm Material	316L SST Hastelloy C276								
Fill Fluid	Silicone								

Performance Specifications (Code L1)

Reference Conditions	Span starting at zero, temperature of 25 °C (77 °F), atmospheric pressure, power supply of 24 Vdc, silicone oil fill fluid, isolating diaphragms in 316L SST and digital trim equal to lower and upper range values.
Accuracy	<p>For all L1 ranges: 0.2 URL ≤ span ≤ URL: ± 0.04% of span 0.05 URL ≤ span < 0.2 URL: ± [0.021667 + 0.003667 URL/span]% of span 0.0085 URL ≤ span < 0.05 URL: ± [0.0021 + 0.004645 URL/span]% of span</p>
Stability	<p>For range 2: ± 0.05% of URL for 6 months For range 3: ± 0.075% of URL for 12 months For range 4: ± 0.1% of URL for 24 months For all M, D, and H transmitters: ± 0.15% of URL for 12 years, at 20 °C temperature change and up to 7 MPa (1000 psi) {70 bar} of static pressure, environment free of hydrogen migration.</p>
Temperature Effect	<p>From -10 °C to 50 °C, protected from direct sun radiation: 0.2 URL ≤ span ≤ URL: ± [0.018% URL + 0.012% span] per 20 °C (36 °F) 0.0085 URL ≤ span < 0.2 URL: ± [0.02% URL + 0.002% span] per 20 °C (36 °F)</p>
Static Pressure Effect	<p>Zero error: ± 0.025% URL per 7 MPa (1000 psi) The zero error is a systematic error that can be eliminated by calibrating at the operating static pressure.</p> <p>Span error: Correctable to ± 0.2% of reading per 7 MPa (1000 psi).</p>

Hastelloy is a trademark of the Cabot Corp.

Fluorolube is a trademark of Hooker Chemical Corp.

Foundation is a trademark of Fieldbus Foundation.

Monel is a trademark of International Nickel Co.

Halocarbon is a trademark of Halocarbon.

Profibus is a trademark of Profibus International.

Viton and Teflon are trademarks of E. I. DuPont de Nemours & Co. HART® is a trademark of HART® Communication Foundation. Smar Pressure Transmitters are protected by US patent number 6,433,791

MODEL DIFFERENTIAL, FLOW, GAGE, ABSOLUTE AND HIGH STATIC PRESSURE TRANSMITTERS

LD301	HART® & 4-20 mA									
LD302	FOUNDATION™ fieldbus									
LD303	PROFIBUS PA									
COD.	Type	Range Limits		Min. Span	Unit	Range Limits		Min. Span	Unit	
		Min	Max			Min	Max			
D0	Differential and Flow	-1	1	0.05	kPa	-4	4	0.2	inH ₂ O	
D1	Differential and Flow	-5	5	0.10	kPa	-20	20	0.4	inH ₂ O	
D2	Differential and Flow	-50	50	0.42	kPa	-200	200	1.67	inH ₂ O	
D3	Differential and Flow	-250	250	2.08	kPa	-36	36	0.3	psi	
D4	Differential and Flow	-2500	2500	20.83	kPa	-360	360	3	psi	
M0	Gage	-1	1	0.05	kPa	-4	4	0.2	inH ₂ O	
M1	Gage	-5	5	0.10	kPa	-20	20	0.4	inH ₂ O	
M2	Gage	-50	50	0.42	kPa	-200	200	1.67	inH ₂ O	
M3	Gage	-100	250	2.08	kPa	-14.50	36	0.3	psi	Note: The range can be extended up to 0.75 LRL and 1.2 URL with small degradation of accuracy.
M4	Gage	-100	2500	20.83	kPa	-14.50	360	3	psi	
M5	Gage	-0.1	25	0.21	MPa	-14.50	3600	30	psi	
M6	Gage	-0.1	40	0.33	MPa	-14.50	5800	48.3	psi	
A1	Absolute	0	5	2.00	kPa	0	37	14.8	mmHga	
A2	Absolute	0	50	2.50	kPa	0	7.2	0.36	psia	
A3	Absolute	0	250	5.00	kPa	0	36	0.73	psia	
A4	Absolute	0	2500	20.83	kPa	0	360	3	psia	
A5	Absolute	0	25	0.21	MPa	0	3600	30	psia	
A6	Absolute	0	40	0.33	MPa	0	5800	48.3	psia	
H2	Differential - High Static Pressure	-50	50	0.42	kPa	-200	200	1.67	inH ₂ O	
H3	Differential - High Static Pressure	-250	250	2.08	kPa	-36	36	0.3	psi	
H4	Differential - High Static Pressure	-2500	2500	20.83	kPa	-360	360	3	psi	
H5	Differential - High Static Pressure	-25	25	0.21	MPa	-3600	3600	30	psi	

COD. Diaphragm Material and Fill Fluid

1	316L SST	Silicone Oil (9)	9	316L SST	Fomblin Oil	M	Monel 400 Gold Plated	Silicone Oil (1) (3) (9)
2	316L SST	Inert Fluorolube Oil (12)(15)	A	Monel 400	Fomblin Oil (1)(3)	P	Monel 400 Gold Plated	Inert Krytox Oil (1) (3) (15)
3	Hastelloy C276	Silicone Oil (1)(9)	D	316 L SST	Inert Krytox Oil (3)(15)	Q	316 L SST	Inert Halocarbon 4.2 Oil (2) (3) (15)
4	Hastelloy C276	Inert Fluorolube Oil (1)(2)(15)	E	Hastelloy C276	Inert Krytox Oil (1)(3)(15)	R	Hastelloy C276	Inert Halocarbon 4.2 Oil (2) (3) (15)
5	Monel 400	Silicone Oil (1)(3)(9)	G	Tantalum	Inert Krytox Oil (3)(15)	S	Tantalum	Inert Halocarbon 4.2 Oil (2) (3) (15)
7	Tantalum	Silicone Oil (3)(9)	I	316L SST, Gold Plated	Silicone Oil	U	316 L SST O.P.	Silicone Oil (9)
8	Tantalum	Inert Fluorolube Oil (2)(3)(15)	K	Monel 400	Inert Krytox Oil (1)(3)(15)			Note: O.P. = Over-Lay Pot

COD. Flange(s), Adapter(s) and Drain/Vent Valves Material

C	Plated CS (Drain/Vent In Stainless Steel) (16)	M	Monel 400 (1)	Z	User's specification
F	Monel 400 Plated Bar (for HF applications)	N	316 SST - CF8M (ASTM A351) (Drain/Vent In Hastelloy C276) (1)		
H	Hastelloy C276 (CW-12MW, ASTM - A494) (1)	P	316 SST - CF8M (ASTM A351) Flange with PVDF (Kynar) Insert (5) (7) (11)		
I	316 SST - CF8M (ASTM A351)	O	316 SST - CF8M (Drain/Vent and plug in Monel) Nace Standard		

COD. Wetted O'Rings Materials

0	Without O'Rings	E	Ethylene - Propylene (12)	T	Teflon	Note: O'Rings are not available on the sides with Remote Seals.
B	Buna-N	K	Kalrez (12)	V	Viton	

COD. Drain/Vent Position

0	Without Drain/Vent	D	Bottom	Note: For better drain/vent operation, vent valves are strongly recommended. Drain/vent valve not available on the sides with remote seals.
A	Drain/Vent (Opposite to Process Connection)	U	Top	

COD. Local Indicator

0	Without Indicator	1	With Digital Indicator
---	-------------------	---	------------------------

COD. Process Connection

0	1/4 - 18 NPT (Without Adapter)	B	High Side: 1/2 - 14 NPT and Low Side: Remote Seal (With Plug) (10) (12)
1	1/2 - 14 NPT (With Adapter)	D	High Side: Remote Seal (With Plug) and Low Side - 1/2 - 14 NPT (10) (12)
2	CF16 (Without Adapter)	F	High Side: 1/2 - 14 NPT and Low Side: Remote Seal (Low Volume Flange) (10)(12)
3	Remote Seal (With Plug) (3) (8)	H	High Side: Remote Seal (Low Volume Flange) and Low Side: 1/2 - 14 NPT (10)(12)
5	1/2 - 14 NPT Axial with PVDF Insert (5)(7)(14)	Q	8 mm hole without thread (According to DIN19213) (13)
6	Low Volume Flange	T	1/2 - 14 BSP (With Adapter)
7	Plug for Remote Seal	U	Low Volume Flange for Level Welded
8	Low Volume Flange - Welded	V	Manifold Valve integrated to the transmitter
9	Remote Seal (Low Volume Flange) (3)(4)(8)	Z	User's specification

COD. Electrical Connection

0	1/2 - 14 NPT (17)(18)(19)(20)	A	M20 X 1.5 (17)(18)
1	3/4 - 14 NPT (with 316 SST adapter for 1/2 - 14 NPT) (17)(20)	B	PG 13.5 DIN (17)(18)
2	3/4 - 14 BSP (with 316 SST adapter for 1/2 - 14 NPT) (6)	Z	User's specification
3	1/2 - 14 BSP (with 316 SST adapter for 1/2 - 14 NPT) (6)		

COD. Set this code as "1" for LD301 and exclude for the others

COD. Mounting Bracket for 2" Pipe or Surface Mounting

0	Without bracket	7	Carbon steel bracket. Accessories: 316 SST (16)
1	Carbon steel bracket and accessories (16)	9	L type, carbon steel bracket. Accessories: 316 SST (16)
2	316 SST bracket and accessories	A	Flat, 304 SST bracket and 316 SST accessories
5	L type, carbon steel bracket and accessories (16)	Z	User's specification
6	L type, 316 SST bracket and accessories		

COD. Continues next page

LD301 - D2 | 1 | I | - B | U | 1 | 0 - 0 | 1 | 2 | / | *

← TYPICAL MODEL NUMBER

LD302 - D2 | 1 | I | - B | U | 1 | 0 - 0 | 2 | / | *

LD303 - D2 | 1 | I | - B | U | 1 | 0 - 0 | 2 | / | *

* Leave blank for no optional items.

- Notes:**
- (1) Meets NACE MR-01-75/ISO 15156 recommendations.
 - (2) Not available for absolute models nor for vacuum applications.
 - (3) Not available for range 0 and 1.
 - (4) Not recommended for vacuum service.
 - (5) Maximum pressure 24 bar.
 - (6) Options not certified for use in hazardous locations.
 - (7) Drain/Vent not applicable.
 - (8) For remote seal only 316 SST - CF8M (ASTM A351) flange is available 7/16 UNF.
 - (9) Silicone Oil is not recommended for oxygen (O₂) or Chlorine service.
 - (10) Only available for differential pressure transmitters.
 - (11) O-ring should be Viton or Kalrez.
 - (12) Not available for range 0.
 - (13) Available for differential pressure transmitters, range 4, 7/16 UNF or M10 x 1.5 thread and for high static pressure transmitters, range 4, 7/16 UNF thread.
 - (14) Only available for flange with PVDF (Kynar) insert
 - (15) Inert Fluid: Safe Oxygen Service.
 - (16) Not applicable for saline atmosphere.
 - (17) This adapter has certified for use in Explosion Proof (CEPEL).
 - (18) This adapter has certified for use in Explosion Proof (NEPSI, NEMKO, EXAM).
 - (19) This adapter has certified for use in Explosion Proof (FM).
 - (20) This adapter has certified for use in Explosion Proof (CSA).

MODEL	DIFFERENTIAL, FLOW, GAGE, ABSOLUTE AND HIGH STATIC PRESSURE TRANSMITTERS						
COD. Flanges Bolts and Nuts Material							
A0	Plated Carbon Steel (Default) (8)		A2	Carbon Steel (ASTM A193 B7M) (1) (8)		A7	Super Duplex Stainless Steel Nace MR0175 / MR0103 Compliant
A1	316 SST		A5	Hastelloy C276			
COD. Flange Thread for Fixing Accessories (Adapters, Manifolds, Mounting Brackets, etc)							
D0	7/16 UNF (Default)		D2	M12 X 1.75			
D1	M10 X 1.5						
COD. Output Signal (Only available for LD301)							
G0	4 - 20 mA (Default)		G3	NAMUR NE43 Extended 4 to 20 mA (Burnout 3.55 and 22.8 mA)			
G1	0 - 20 mA (4-wire) (2)						
COD. Housing Material (10) (11)							
H0	Aluminum (Default) (IP/TYPE)		H3	316 SST for Saline Atmospheres (IPW/TYPEX) (9)			
H1	316 SST - CF8M (ASTM - A351) (IP/TYPE)		H4	Aluminium Copper Free (IPW/TYPEX) (9)			
H2	Aluminium for Saline Atmospheres (IPW/TYPEX) (9)						
COD. Tag Plate							
J0	With tag, when specified (Default)		J1	Blank		J2	User's Specification
COD. PID Configuration - (Only available for LD301)							
M0	With PID (Default)						
M1	Without PID						
COD. LCD1 Indication (Only available for LD301)							
Y0	LCD1: Percentage (Default)		Y3	LCD1: Temperature (Engineering Unit)			
Y1	LCD1: Current - I (mA)		YU	LCD1: User's Specification (4)			
Y2	LCD1: Pressure (Engineering Unit)						
COD. LCD2 Indication (Only available for LD301)							
Y0	LCD2: Percentage (Default)		Y6	LCD2: Temperature (Engineering Unit)			
Y4	LCD2: Current - I (mA)		YU	LCD2: User's Specification (4)			
Y5	LCD2: Pressure (Engineering Unit)						
COD. Identification Plate							
I1	FM: XP, IS, NI, DI		I6	Without Certification			
I2	NEMKO: Ex-d, Ex-ia (7)		I7	Dekra/EXAM: Group I, M1 Ex-ia			
I3	CSA: XP, IS, NI, DI		I8	0 to 20 mA: LD301 (2)			
I4	EXAM (DTM): Ex-ia, NEMKO: Ex-d		ID	NEPSI: Ex-ia, Ex-d			
I5	CEPEL: Ex-d, Ex-ia		IE	NEPSI: Ex-ia (5)			
COD. Painting							
P0	Gray Munsell N 6,5 Polyester		P8	Without Painting			
P3	Black Polyester		P9	Safety Blue Epoxy - Electrostatic Painting			
P4	White Epoxy		PC	Safety Blue Polyester - Electrostatic Painting			
P5	Yellow Polyester		PG	Safety Orange Epoxy Paint - Electrostatic Painting			

LD301-D21I-BU10-012	A0	D0	G0	H0	J0	M0	Y0	Y5	I6	P0
LD302-D21I-BU10-02	A0	D0		H0	J0				I6	P0
LD303-D21I-BU10-02	A0	D0		H0	J0				I6	P0

← TYPICAL MODEL NUMBER

Optional Items

Burn-out (Only available for LD301)	BD - Down Scale (According to NAMUR NE43 specification) BU - Up Scale (According to NAMUR NE43 specification)
Special Applications	C1 - Degrease Cleaning (Oxygen or Chlorine Service) (5)
High Performance	L1- 0.04% accuracy (3)
Square Root Extraction (Only available for LD301D)	M3 - Configured with Square Root Extraction
Special Features	ZZ - User's specification

Notes:

- (1) Meets NACE MR-01-75/ISO 15156 recommendations.
- (2) Without Explosion Proof or Intrinsic Safety approvals.
- (3) Only available for differential and gage pressure models.
- (4) Values limited to 4 1/2 digits; unit limited to 5 characters.
- (5) Degrease cleaning not available for carbon steel flanges.
- (6) Only available for LD302 and LD303 models.
- (7) Only available for LD301.
- (8) Not applicable for saline atmosphere.

- (9) IPW/TYPEX tested for 200 hours according to NBR 8094 / ASTM B 117 standard.
- (10) IPX8 tested in 10 meters of water column for 24 hours.
- (11) Ingress Protection:

Products	CEPEL	NEMKO / EXAM	FM	CSA	NEPSI
LD300	IP66/68/W	IP66/68/W	Type 4X/6P	Type 4X	IP67

MODEL										FLANGED PRESSURE TRANSMITTER									
LD301										HART®									
LD302										FOUNDATION™ fieldbus									
LD303										PROFIBUS PA									
COD.		Range Limits		Min. Span	Unit.	Range Limits		Min. Span	Unit.	Note: The range can be extended up to 0.75 LRL and 1.2 URL with small degradation of accuracy. The upper range value must be limited to the flange rating.									
		Min.	Max.			Min.	Max.												
L2		-50	50	1.25	kPa	-200	200	5	inH ₂ O										
L3		-250	250	2.08	kPa	-36	36	0.3	psi										
L4		-2500	2500	20.83	kPa	-360	360	3	psi										
L5		-25000	25000	208.30	kPa	-3625	3625	30.2	psi										
COD. Diaphragm material and Fill Fluid (Low Side)																			
1	316L SST	Silicone Oil (2)			8	Tantalum	Inert Fluorolube Oil (3) (26)				K	Monel 400	Inert Krytox Oil (1) (26)						
2	316L SST	Inert Fluorolube Oil (3) (26)			9	316L SST	Fomblim Oil				M	Monel 400 Gold Plated	Silicone Oil (1) (2)						
3	Hastelloy C276	Silicone Oil (1) (2)			A	Monel 400	Fomblim Oil (1)				P	Monel 400 Gold Plated	Inert Krytox Oil (1) (26)						
4	Hastelloy C276	Inert Fluorolube Oil (1) (3) (26)			D	316L SST	Inert Krytox Oil (26)			Q	316L SST	Inert Halocarbon 4.2 Oil (26)							
5	Monel 400	Silicone Oil (1) (2)			E	Hastelloy C276	Inert Krytox Oil (1) (26)			R	Hastelloy C276	Inert Halocarbon 4.2 Oil (1) (26)							
7	Tantalum	Silicone Oil (2)			G	Tantalum	Inert Krytox Oil (26)			S	Tantalum	Inert Halocarbon 4.2 Oil (26)							
COD. Flange, Adapter and Drain/Vent Valves material (Low Side)																			
A	304L SST				I	316 SST – CF8M (ASTM – A351)													
C	Plated CS (Drain/Vent in Stainless Steel) (22)				M	Monel 400 (1)													
F	Monel 400 Plated Bar (for HF applications)				N	316 SST – CF8M (ASTM – A351) (Drain/Vent in Hastelloy C276) (1)													
H	Hastelloy C276 (CW – 12MW, ASTM – A494) (1)				P	316 SST – CF8M (ASTM – A351) Flange with PVDF (Kynar) insert (3) (4) (5)													
COD. Wetted O'Ring Material (Low Side)																			
0	Without O'Rings			E	Ethylene - Propylene			T	Teflon		Note: O'rings are not available on the sides with remote seals.								
B	Buna-N			K	Kalrez			V	Viton										
COD. Drain/Vent Position (Low Side)																			
0	Without Drain/Vent				D	Low		Note: For better Drain/Vent operation, vent valves are strongly recommended.											
A	Drain/Vent (Opposite to Process Connection)				U	Upper		Drain/Vent valve are not available on the sides with remote seals											
COD. Local Indicator																			
0	Without Indicator				1	With Digital indicator													
COD. Process Connection (Low Side)																			
0	1/4 - 18 NPT (Without Adapter)				6	Low Volume Flange - 1/4 NPT			U	Low Volume Flange for Level Welded									
1	1/2 - 14 NPT (Without Adapter)				7	Plug for Remote Seal			V	Without Connection (Mounted with Gage Flange)									
2	CF16 (Without Adapter)				8	Low Volume Flange - Welded			W	Without Connection (Absolute Reference)									
3	Remote Seal (With Plug) (7)				9	Remote Seal (Low Volume Flange) (3) (7)													
5	1/2 - 14 NPT Axial with PVDF Insert (3) (4) (6)				T	1/2 14 BSP (With Adapter)													
COD. Electrical Connection																			
0	1/2 – 14 NPT (24)(29)(30)(31)				A	M20 x 1.5 (24)(29)													
1	3/4 – 14 NPT (with 316 SST adapter for 1/2 - 14 NPT) (24)(31)				B	PG 13.5 DIN (24)(29)													
2	3/4 – 14 BSP (with 316 SST adapter for 1/2 - 14 NPT) (9)				Z	User's specification													
3	1/2 – 14BSP (with 316 SST adapter for 1/2 - 14 NPT) (9)																		
COD. Zero and Span Adjust																			
1	With Zero and Span Adjustment																		
COD. Process Connection																			
U	1" 150 # (ANSI B16.5) (33)			B	2" 600 # (ANSI B16.5)			5	DN 25 PN 10/40 (33)		T	JIS 50A 40K (21)							
V	1" 300 # (ANSI B16.5) (33)			1	3" 150 # (ANSI B16.5)			R	DN 40 PN 10/40		K	JIS 50A 20K (21)							
W	1" 600 # (ANSI B16.5) (33)			2	3" 300 # (ANSI B16.5)			E	DN 50 PN 10/40		G	JIS 80A 10K (21)							
O	1.1/2" 150 # (ANSI B16.5)			C	3" 600 # (ANSI B16.5)			6	DN 80 PN 10/40		L	JIS 80A 20K (21)							
P	1.1/2" 300 # (ANSI B16.5)			N	3" 600 # (ANSI B16.5 RTJ)			7	DN 100 PN 10/16		H	JIS 100A 10K (21)							
Q	1.1/2" 600 # (ANSI B16.5)			3	4" 150 # (ANSI B16.5)			8	DN 100 PN 25/40		M	JIS 100A 20K (21)							
9	2" 150 # (ANSI B16.5)			4	4" 300 # (ANSI B16.5)			S	JIS 40A 20K (21)		Z	User's specification							
A	2" 300 # (ANSI B16.5)			D	4" 600 # (ANSI B16.5)			F	JIS 50A 10K (21)										
COD. Material and Flange Type (Level Tap)																			
2	316L SST (Integral Flange)			3	Hastelloy C276 (Integral Flange)			5	316 SST (Slip-on Flange)										
Z	User's specification			4	304 SST (Slip-on Flange)			6	Carbon Steel (Slip-on Flange)										
COD. Extension Length																			
0	0 mm (0")		2	100 mm (4")		4	200 mm (8")		Note: Extension Material 316L SST										
1	50 mm (2")		3	150 mm (6")		Z	User's specification												
COD. Diaphragm Material / Extension (Level Tap)																			
A	304L SST / 304L SST			4	Tantalum / 316 SST (10)			B	Tantalum with Teflon Lining										
1	316L SST / 316 SST			5	Titanium / 316 SST (10)			C	Hastelloy with Teflon Lining										
2	Hastelloy C276 / 316 SST			6	316L SST with Teflon Lining (for 2" and 3")			L	316L Stainless Steel with Halar Lining (20)										
3	Monel 400 / 316 SST			7	316L SST with Gold Lining														
COD. Fill Fluid (Level Tap)																			
1	DC 200 Silicone Oil			T	Syltherm 800 Oil			H	Halocarbon 4.2										
3	DC 704 Silicone Oil			N	Neobee M20 Propylene Glycol Oil			G	Glycerin + Water (11)										
2	MO – 10 Fluorolube Oil (8)			4	Krytox Oil			B	Fomblim 06/06										
COD. Lower Housing Material																			
0	Without Lower Housing (12)				3	Super Duplex (UNS 32750) (11)													
1	Stainless Steel 316				4	Duplex (UNS 31803) (11)													
2	Hastelloy C276				M	Monel													
COD. Gasket Material																			
0	Without gasket			G	Grafoil (Flexible lead)			I	Stainless 316 L										
T	Teflon (PTFE)			C	Copper														
COD. Continues Next Page																			

LD301	L2	1	I	B	U	1	0	0	1	1	2	2	1	1	1	1	T	/	*
LD302	L2	1	I	B	U	1	0	0	1	1	2	2	1	1	1	1	T	/	*
LD303	L2	1	I	B	U	1	0	0	1	1	2	2	1	1	1	1	T	/	*

← TYPICAL MODEL NUMBER

* Leave it blank when there are not optional items.

MODEL	FLANGED PRESSURE TRANSMITTER										
	COD. Flanges Bolts and Nuts Material										
	A0	Plated Carbon Steel (Default) (22)				A2	Carbon Steel (ASTM A193 B7M) (1) (22)				
	A1	316 SST				A5	Hastelloy C276				
	COD. Flange Thread for Fixing Accessories (Adapters, Manifolds, Mounting Brackets, etc)										
	D0	7/16 UNF (Default)				D2	M12 X 1.75				
	D1	M10 X 1.5									
	COD. Flange Facing Finish (18)										
	Q0	Raised Face - RF (Default)				Q3	Tongue Face (11)				
	Q1	Flat Face - FF				Q4	Grooved Face (11)				
	Q2	Ring Joint Face - RTJ (Only available for ANSI standard flange) (17)									
	COD. Output Signal (Only available for LD301)										
	G0	4 - 20 mA (Default)				G3	NAMUR NE43 Extended 4 to 20 mA (Burnout 3.55 and 22.8 mA)				
	G1	0 - 20 mA (4-wire) (13)									
	COD. Housing Material (27) (28)										
	H0	Aluminum (Default) (IP/TYPE)				H3	316 SST for Saline Atmospheres (IPW/TYPEX) (23)				
	H1	316 SST - CF8M (ASTM - A351) (IP/TYPE)				H4	Aluminium Copper Free (IPW/TYPEX) (23)				
	H2	Aluminium for Saline Atmospheres (IPW/TYPEX) (23)									
	COD. Tag Plate										
	J0	With tag, when specified (Default)				J1	Blank		J2	User's Specification	
	COD. PID Configuration - (Only available for LD301)										
	M0	With PID (Default)									
	M1	Without PID									
	COD. LCD1 Indication (Only available for LD301)										
	Y0	LCD1: Percentage (Default)				Y3	LCD1: Temperature (Engineering Unit)				
	Y1	LCD1: Current - I (mA)				YU	LCD1: User's Specification (14)				
	Y2	LCD1: Pressure (Engineering Unit)									
	COD. LCD2 Indication (Only available for LD301)										
	Y0	LCD2: Percentage (Default)				Y6	LCD2: Temperature (Engineering Unit)				
	Y4	LCD2: Current - I (mA)				YU	LCD2: User's Specification (14)				
	Y5	LCD2: Pressure (Engineering Unit)									
	COD. Identification Plate										
	I1	FM: XP, IS, NI, DI				I6	Without Certification				
	I2	NEMKO: Ex-d, Ex-ia (32)				I7	Dekra/EXAM: Group I, M1 Ex-ia				
	I3	CSA: XP, IS, NI, DI				I8	0 to 20 mA: LD301 (13)				
	I4	EXAM (DTM): Ex-ia, NEMKO: Ex-d				ID	NEPSI: Ex-ia, Ex-d				
	I5	CEPEL: Ex-d, Ex-ia				IE	NEPSI: Ex-ia (5)				
	COD. Painting										
	P0	Gray Munsell N 6,5 Polyester									
	P3	Black Polyester									
	P4	White Epoxy									
	P5	Yellow Polyester									
	P8	Without Painting									
	P9	Safety Blue Epoxy - Electrostatic Painting									
	PC	Safety Blue Polyester - Electrostatic Painting									
	PG	Safety Orange Epoxy Paint - Electrostatic Painting									

LD301-L21I-BU10-01-122111-T /	A0	D0	Q0	G0	H0	J0	M0	Y0	Y5	I6	P0
LD302-L21I-BU10-01-122111-T /	A0	D0	Q0		H0	J0				I6	P0
LD303-L21I-BU10-01-122111-T /	A0	D0	Q0		H0	J0				I6	P0

← TYPICAL MODEL NUMBER

Optional Items

Burnout	BD - Down Scale (Accordance to NAMUR NE43 specification)	BU - Up Scale (Accordance to NAMUR NE43 specification)
Special Procedures	C1 - Degrease Cleaning (Oxygen or Chlorine Service) (15)	C2 - For Vacuum Application
Special Features	ZZ - User's Specification.	
Gasket Connection	U0 - With Flush Connection of 1/4" NPT (If supplied with housing) U1 - With Two Flush Connections of 1/4" NPT at 180° U2 - With Two Flush Connections of 1/4" NPT at 90°	U3 - With Two Connections of 1/2" NPT - 14 NPT at 180° (With Lid) U4 - Without gasket connection
Insulator Kit	K0 - Without Kit	K1 - With Kit
Diaphragm Thickness (16)	N0 - Default (25)	N1 - 0.1mm (11)

Notes - LD300L:

- (1) Meets NACE MR – 01 – 75/ISO 15156 recommendations.
 (2) Silicone oil not recommended for Oxygen (O2) or Chlorine Service.
 (3) Not applicable for vacuum service.
 (4) Drain/Vent is not applicable.
 (5) O-ring material must be of Viton or Kalrez.
 (6) Maximum pressure 24 bar.
 (7) For remote seal is only available flange in 316 stainless steel– CF8M (ASTM A351) (thread M12).
 (8) Fluorolube fills fluid not available with Monel diaphragm.
 (9) Options not certified for use in hazardous locations.
 (10) Attention, check corrosion rate for the process, tantalum plate 0.1 mm, AISI 316L extension 3 to 6mm.
 (11) Item by inquiry.
 (12) Supplied without Gasket.
 (13) Without certification for Explosion proof certification or Intrinsically safe.
 (14) Limited values to 4 1/2 digits; limited unit to 5 characters.
 (15) Degreaser's cleaning is not available for carbon steel flanges .
 (16) The insulator kit is applicable with Raised Face (HO) and Smooth Face (H1) with Gasket material. T (Teflon) and only for the following models: - ANSI until #600 , DIN until P40 and JIS until 40K;
 - For models with extension the Gasket T (Teflon) it has special share.
 (17) Gasket for housing, available only in Stainless 316.
 (18) Finishing flange faces:
 ANSI B 16.5 / MSS-SP6:
 - Raised or Smooth Face with gooved lining: 3.2 to 6.3 µm Ra (125 a 250 µ" AA);
 - Small or Large Tongue Face and Small or Large Groove with smooth finishing not exceeding: 3.2 µm Rt (125 µ" AA);
 RTJ ANSI B 16.20 / MSS-SP6:
 -Smooth finishing not exceeding: 1.6 µm Rt (63 µ" AA);
 DIN EN-1092-1:
 - Grooved finishing "B1" (PN 10 a PN40): 3.2 a 12.5 µm Ra (125 a 500 µ" AA);
 - Smooth finishing "B2" (PN 63 a PN100), "C" (Tongue) e "D" (Groove): 0.8 a 3.2 µm Ra (32 a 125 µ" AA).
 Din 2501 (DIN 2526);
 - Smooth finishing "E" (PN 160 a PN250): Rz = 16 (3.2 µm Ra (125 µ" AA).
 Standard Jis B2201
 - Grooved finishing 3.2 a 6.3 µm Ra (125 a 250 µ" AA).
 (19) Temperature application range:
 -40 to 150°C.
 (20) Applicable only for:
 - Diaphragm Thickness of 0.05mm.
 - Diameters/Capillary Length:
 2" ANSI B 16.5, DN 50 DIN, JIS 50 A, for seals up to 3 meters of capillary and level models (by inquiry).
 3" ANSI B 16.5, DN 80 DIN, JIS 80 A, for seals up to 5 meters of capillary and level models.
 4" ANSI B 16.5, DN 100 DIN, JIS 100 A, for seals up to 8 meters of capillary and level models.
 - Faces: RF and FF.
 - Temperature Limits:
 +10 to 100°C;
 +101 to 150°C (by inquiry).
 - Not applicable for diaphragm thickness: N1 - 0.10mm.
 - Not applicable for use with housing.
 (21) Not available for slip-on flange.
 (22) Not applicable for saline atmosphere.
 (23) IPW/TYPEX tested for 200 hours according to NBR 8094 / ASTM B 117 standard.
 (24) Certificate for use in explosive atmosphere (CEPEL).
 (25) Diaphragms of Titanium and Monel available only in 0.1 mm, and diaphragms of Tantalum only in 0.075 mm.
 (26) Inert Fluid: Safe Oxygen service.
 (27) IPX8 tested in 10 meters of water column for 24 hours.
 (28) Ingress Protection:

Products	CEPEL	NEMKO / EXAM	FM	CSA	NEPSI
LD300	IP66/68/W	IP66/68/W	Type 4X/6P	Type 4X	IP67

- (29) This adapter has certified for use in Explosion Proof (NEPSI, NEMKO, EXAM).
 (30) This adapter has certified for use in Explosion Proof (FM).
 (31) This adapter has certified for use in Explosion Proof (CSA).
 (32) Only available for **LD301**.
 (33) Not available for integral flange.

MODEL	PRESSURE SANITARY TRANSMITTER											
LD301	HART®											
LD302	FOUNDATION™ fieldbus											
LD303	PROFIBUS PA											
COD.	Range Limits				Min. Span	Unit.	Range Limits				Min. Span	Unit.
	Min.	Max.	Min.	Max.			Min.	Max.	Min.	Max.		
S2	-50	50	1.25	kPa			-200	200	5	inH ₂ O	Nota: The range can be extended up to 0.75 LRL and 1.2 URL with small degradation of accuracy. The upper range value must be limited to the connection.	
S3	-250	250	2.08	kPa			-36	36	0.3	psi		
S4	-2500	2500	20.83	kPa			-360	360	3	psi		
S5	-25000	25000	208.30	kPa			-3625	3625	30.2	psi		
COD. Diaphragm Material and Fill Fluid (Low Side)												
1	316L SST	Silicone Oil (2)	8	Tantalum	Inert Fluorolube Oil (3) (19)	K	Monel 400	Inert Krytox Oil (1) (19)				
2	316L SST	Inert Fluorolube Oil (3) (19)	9	316L SST	Fomblim Oil	M	Monel 400 Gold Plated	Silicone Oil (1) (2)				
3	Hastelloy C276	Silicone Oil (1) (2)	A	Monel 400	Fomblim Oil (1)	P	Monel 400 Gold Plated	Inert Krytox Oil (1) (19)				
4	Hastelloy C276	Inert Fluorolube Oil (1) (3) (19)	D	316L SST	Inert Krytox Oil (19)	Q	316L SST	Inert Halocarbon 4.2 Oil (19)				
5	Monel 400	Silicone Oil (1) (2)	E	Hastelloy C276	Inert Krytox Oil (1) (19)	R	Hastelloy C276	Inert Halocarbon 4.2 Oil (1) (19)				
7	Tantalum	Silicone Oil (2)	G	Tantalum	Inert Krytox Oil (19)	S	Tantalum	Inert Halocarbon 4.2 Oil (19)				
COD. Flange(s), Adapter (s) and Drain Valve(s) Material (Low Side)												
C	Plated CS (Drain/Vent in Stainless Steel) (18)					M	Monel 400 (1)					
H	Hastelloy C276 (CW – 12MW, ASTM – A494) (1)					N	316 SST – CF8M (ASTM – A351) (Drain/Vent in Hastelloy C276) (1)					
I	316 SST – CF8M (ASTM – A351)					P	316 SST – CF8M (ASTM – A351) Flange with PVDF (Kynar) insert (3) (4) (5)					
COD. Wetted O-Ring Material (Low Side)												
0	Without O-Ring			E	Ethylene - Propylene			V	Viton			Note: O-Rings are not available on the sides with remote seal.
B	Buna-N			T	Teflon (Approved 3A) (21)			K	Kalrez			
COD. Drain Position (Low Side)												
0	Without Drain				D	Bottom		Note: For better drain operation, drain valves are strongly recommended. Drain valve are not available on the sides with remote seal				
A	Drain (Opposite to process connection)				U	Top						
COD. Local Indicator												
0	Without Indicator					1	With Digital Indicator					
COD. Process Connection (Low Side)												
0	1/4 - 18 NPT (Without Adapter)			6	Low Volume Flange - 1/4 NPT			U	Low Volume Flange for Level Welded			
1	1/2 - 14 NPT (Without Adapter)			7	Plug for Remote Seal			V	Without Connection (Mounted with Gage Flange)			
2	CF16 (Without Adapter)			8	Low Volume Flange - Welded			W	Without Connection (Absolut Reference)			
3	Remote Seal (With Plug) (7)			9	Remote Seal (Low Volume Flange) (3) (7)							
5	1/2 - 14 NPT Axial with PVDF Insert (3) (4) (6)			T	1/2 14 BSP (With Adapter)							
COD. Electrical Connection												
0	1/2 - 14 NPT (20)(23)(24)(25)					A	M20 X 1.5 (20)(23)					
1	3/4 - 14 NPT (With 316 SST adapter for 1/2 - 14 NPT) (20)(25)					B	PG 13.5 DIN (20)(23)					
2	3/4 - 14 BSP (With 316 SST adapter for 1/2 - 14 NPT) (9)					Z	User's Specification					
3	1/2 - 14 BSP (With 316 SST adapter for 1/2 - 14 NPT) (9)											
COD. Zero and Span Adjust												
1	With Local Adjustment											
COD. Process Connection												
8	Threaded DN25 DIN 11851 - with ext. / 316L SST (10) (11)					E	Threaded SMS 2" - without ext. / 316L SST (10) (11)					
9	Threaded DN40 DIN 11851 - with ext. / 316L SST (10) (11)					M	Threaded SMS 3" - without ext. / 316L SST (10) (11)					
H	Threaded DN40 DIN 11851 - without ext. / 316L SST (10)					1	Threaded SMS 3" - without ext. / 316L SST (10) (11)					
V	Threaded DN50 DIN 11851 - with ext. / 316L SST (10) (11)					F	Tri-Clamp 1 1/2" - without ext. / 316L SST (11)					
U	Threaded DN50 DIN 11851 - without ext. / 316L SST (10)					Q	Tri-Clamp 1 1/2" HP - without ext. / 316L SST (8) (11)					
X	Threaded DN80 DIN 11851 - with ext. / 316L SST (10) (11)					6	Tri-Clamp 2" - without ext. / 316L SST (11)					
W	Threaded DN80 DIN 11851 - without ext. / 316L SST (10)					D	Tri-Clamp 2" - without ext. / 316L SST (11)					
4	Threaded IDF 2" - with ext. / 316L SST (10) (11)					N	Tri-Clamp 2" HP - without ext. / 316L SST (8) (11)					
B	Threaded IDF 2" - without ext. / 316L SST (10) (11)					P	Tri-Clamp 2" HP - without ext. / 316L SST (8) (11)					
K	Threaded IDF 3" - with ext. / 316L SST (10) (11)					I	Tri-Clamp 3" - without ext. / 316L SST (11)					
3	Threaded IDF 3" - without ext. / 316L SST (10) (11)					G	Tri-Clamp 3" - without ext. / 316L SST (11)					
5	Threaded RJT 2" - with ext. / 316L SST (10) (11)					J	Tri-Clamp 3" HP - without ext. / 316L SST (8) (11)					
C	Threaded RJT 2" - without ext. / 316L SST (10)					R	Tri-Clamp 3" HP - without ext. / 316L SST (8) (11)					
L	Threaded RJT 3" - with ext. / 316L SST (10) (11)					Z	User's specification					
2	Threaded RJT 3" - without ext. / 316L SST (10)											
S	Threaded SMS 1 1/2" - without ext. / 316L SST (10) (11)											
7	Threaded SMS 2" - with ext. / 316L SST (10) (11)											
<p style="text-align: right;">Note: ext. = extension HP = High Pressure</p>												
COD. Diaphragm Material (High Side)												
H	Hastelloy C276					I	316L SST					
COD. Fill Fluid												
S	DC 200 – Silicone Oil			T	Syltherm 800			H	Halocarbon 4.2			
D	DC 704 – Silicone Oil			N	Neobee M20 (11)			G	Glycerin + Water (12)			
F	Fluorolube MO-10			K	Krytox 1506			B	Fomblim 06/06			
COD. Wet O-ring												
0	Without O-ring			T	Teflon (11)			B	Buna-N (11)			
								V	Viton (11)			
COD. Tank Adapter												
0	Without Tank Adapter											
1	With Tank Adapter in 316 SST											
COD. Tri-Clamp												
0	Without Tri-Clamp											
2	With Tri-Clamp in 304 SST											
COD. Continues next page												

LD301	S2	1	I	B	U	1	0	0	1	A	I	S	T	1	2	*
LD302	S2	1	I	B	U	1	0	0	1	A	I	S	T	1	2	*
LD303	S2	1	I	B	U	1	0	0	1	A	I	S	T	1	2	*

← TYPICAL MODEL NUMBER

* Leave it blank when there are not optional items.

MODEL		PRESSURE SANITARY TRANSMITTER	
COD. Flanges Bolts and Nuts Material			
A0	Plated Carbon Steel (Default) (18)	A2	Carbon Steel (ASTM A193 B7M) (1) (18)
A1	316 SST	A5	Hastelloy C276
COD. Flange Thread for Fixing Accessories (Adapters, Manifolds, Mounting Brackets, etc)			
D0	7/16 UNF (Default)	D2	M12 X 1.75
D1	M10 X 1.5		
COD. Output Signal (Only available for LD301)			
G0	4 - 20 mA (Default)	G3	NAMUR NE43 Extended 4 to 20 mA (Burnout 3.55 and 22.8 mA)
G1	0 - 20 mA (4-wire) (13)		
COD. Housing Material (21) (22)			
H0	Aluminum (Default) (IP/TYPE)	H3	316 SST for Saline Atmospheres (IPW/TYPEX) (19)
H1	316 SST - CF8M (ASTM - A351) (IP/TYPE)	H4	Aluminium Copper Free (IPW/TYPEX) (19)
H2	Aluminium for Saline Atmospheres (IPW/TYPEX) (19)		
COD. Tag Plate			
J0	With tag, when specified (Default)	J1	Blank
		J2	User's Specification
COD. PID Configuration - (Only available for LD301)			
M0	With PID (Default)		
M1	Without PID		
COD. LCD1 Indication (Only available for LD301)			
Y0	LCD1: Percentage (Default)	Y3	LCD1: Temperature (Engineering Unit)
Y1	LCD1: Current - I (mA)	YU	LCD1: User's Specification (14)
Y2	LCD1: Pressure (Engineering Unit)		
COD. LCD2 Indication (Only available for LD301)			
Y0	LCD2: Percentage (Default)	Y6	LCD2: Temperature (Engineering Unit)
Y4	LCD2: Current - I (mA)	YU	LCD2: User's Specification (14)
Y5	LCD2: Pressure (Engineering Unit)		
COD. Identification Plate			
I1	FM: XP, IS, NI, DI	I6	Without Certification
I2	NEMKO: Ex-d, Ex-ia (26)	I7	Dekra/EXAM: Group I, M1 Ex-ia
I3	CSA: XP, IS, NI, DI	I8	0 to 20 mA: LD301 (13)
I4	EXAM (DTM): Ex-ia, NEMKO: Ex-d	ID	NEPSI: Ex-ia, Ex-d
I5	CEPEL: Ex-d, Ex-ia	IE	NEPSI: Ex-ia (5)
COD. Painting			
P0	Gray Munsell N 6,5 Polyester	P8	Without Painting
P3	Black Polyester	P9	Safety Blue Epoxy - Electrostatic Painting
P4	White Epoxy	PC	Safety Blue Polyester - Electrostatic Painting
P5	Yellow Polyester	PG	Safety Orange Epoxy Paint - Electrostatic Painting

LD301-S21I-BU10-01-AIST12 /	A0	D0	G0	H0	J0	M0	Y0	Y5	I6	P0
LD302-S21I-BU10-01-AIST12 /	A0	D0		H0	J0				I6	P0
LD303-S21I-BU10-01-AIST12 /	A0	D0		H0	J0				I6	P0

← TYPICAL MODEL NUMBER

Optional Items

Burn-out	BD – Down Scale (Accordance to NAMUR NE43 specification) BU – Up Scale (Accordance to NAMUR NE43 specification)
Special Procedures	C1 – Degrease Cleaning (Oxygen or Chlorine Service) (15) C2 – For Vacuum Application C4 – Polishing of the wet parts according to 3A Certification (11) (12)
Special Features	ZZ – User's Specification
Diaphragm Thickness	N0 – Default N1 – 0.1mm (12)

Note - LD300S:

- (1) Meets NACE MR-01-75/ISO 15156 recommendations.
- (2) Silicone oil not recommended for Oxygen (O2) or Chlorine Service.
- (3) Not applicable for vacuum service.
- (4) Drain not applicable.
- (5) O-Ring material must be of Viton or Kalrez.
- (6) Maximum pressure 24 bar.
- (7) For remote seal is only available flange in 316 Stainless Steel - CF8M (ASTMA351) (thread M12).
- (8) HP – High Pressure.
- (9) Options not certified for use in hazardous locations.
- (10) Not available for Tri-clamp.
- (11) Compliant with 3A-7403 standard for food and other applications where sanitary connections are required:
 - Neobee M20 Fill Fluid
 - Finishing wet Face: 0,8 µm Ra (32 µ" AA)
 - Wet O-Ring: Viton, Buna-N and Teflon
- (12) Item by inquiry.
- (13) Without certification for explosion proof or intrinsically safe.
- (14) Limited values to 4 1/2 digits; limited unit to 5 characters.

- (15) Degrease cleaning is not available for Carbon Steel Flanges.
- (16) Temperature application range: -40 to 140 °C and Tables 5 and 6 from the following page.
- (17) Inert Fluid: Safe Oxygen service.
- (18) Not applicable for saline atmosphere.
- (19) IPW/TYPEX tested for 200 hours according to NBR 8094 / ASTM B 117 standard.
- (20) Certificate for use in Explosion Proof (CEPEL).
- (21) IPX8 tested in 10 meters of water column for 24 hours.
- (22) Ingress Protection:

Products	CEPEL	NEMKO / EXAM	FM	CSA	NEPSI
LD300	IP66/68/W	IP66/68/W	Type 4X/6P	Type 4X	IP67

- (23) This adapter has certified for use in Explosion Proof (NEPSI, NEMKO, EXAM).
- (24) This adapter has certified for use in Explosion Proof (FM).
- (25) This adapter has certified for use in Explosion Proof (CSA).
- (26) Only available for LD301.

LD300 - Differential, Flow, Gage, Absolute and High Static Pressure Transmitters with Mounting Bracket

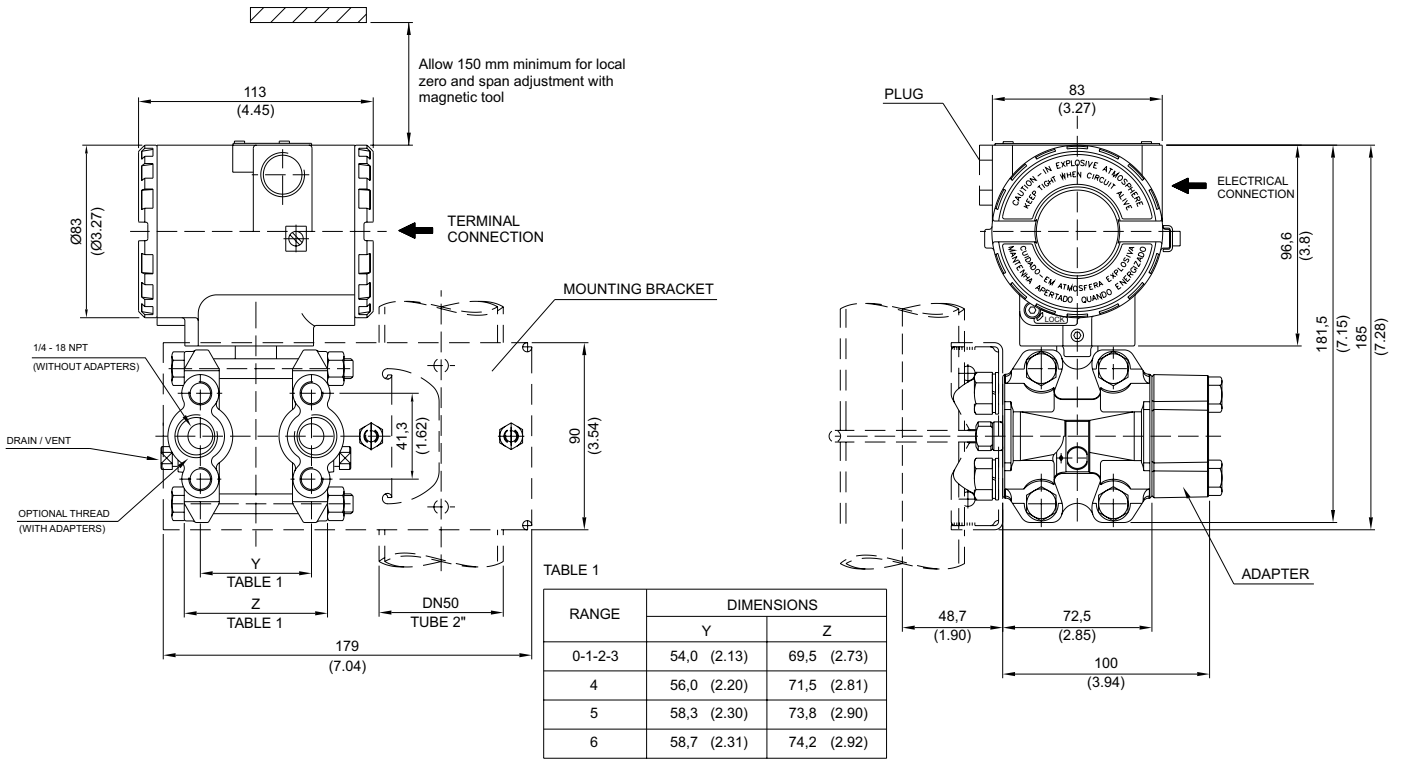

Flanged Pressure Transmitter with Integral Flange

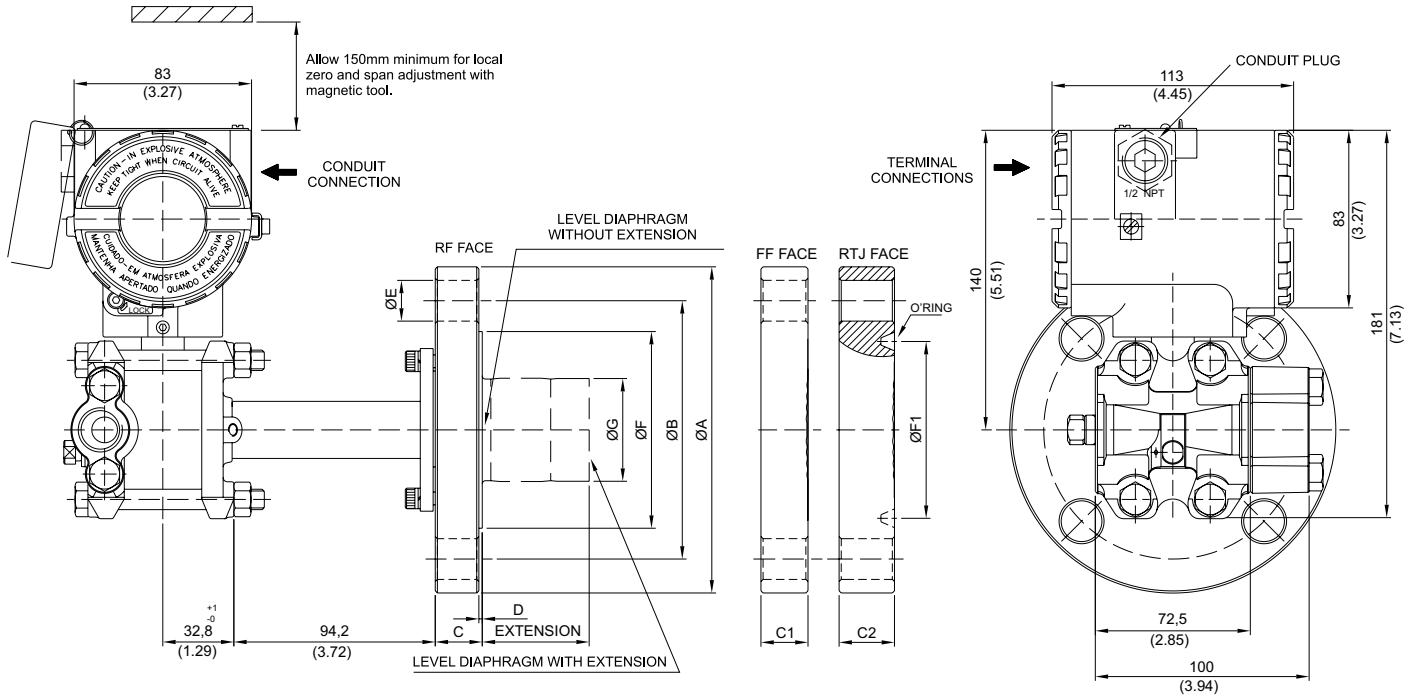

Notes:
 - Extension length (mm): 0, 50, 100, 150 or 200
 - Dimensions are mm (in)

ANSI-B 16.5 DIMENSIONS														
DN	CLASS	A	B	C (RF)	C1 (FF)	C2 (RTJ)	D (RF)	E	F (RF)	F1 (RTJ)	RTJ O-RING	G	HOLES	
1.1/2"	150	127 (5)	98.6 (3.88)	20 (0.78)	19 (0.75)	24.4 (0.96)	1.6 (0.06)	16 (0.63)	73.2 (2.88)	65.1 (2.56)	R19	40 (1.57)	4	
	300	155.4 (6.12)	114.3 (4.5)	21 (0.83)	21 (0.83)	27.4 (1.07)	1.6 (0.06)	22 (0.87)	73.2 (2.88)	68.3 (2.68)	R20	40 (1.57)	4	
	600	155.4 (6.12)	114.3 (4.5)	29.3 (1.15)	29.3 (1.15)	29.3 (1.15)	6.4 (0.25)	22 (0.87)	73.2 (2.88)	68.3 (2.68)	R20	40 (1.57)	4	
2"	150	152.4 (6)	120.7 (4.75)	22 (0.87)	20 (0.78)	25.9 (1.02)	1.6 (0.06)	19 (0.75)	91.9 (3.62)	82.6 (3.25)	R22	48 (1.89)	4	
	300	165.1 (6.5)	127 (5)	22.8 (0.9)	22.8 (0.89)	30.8 (1.21)	1.6 (0.06)	19 (0.75)	91.9 (3.62)	82.6 (3.25)	R23	48 (1.89)	8	
	600	165.1 (6.5)	127 (5)	32.3 (1.27)	32.3 (1.27)	32.3 (1.27)	6.4 (0.25)	19 (0.75)	91.9 (3.62)	82.6 (3.25)	R23	48 (1.89)	8	
3"	150	190.5 (7.5)	152.4 (6)	24.4 (0.96)	24.4 (0.96)	30.7 (1.21)	1.6 (0.06)	19 (0.75)	127 (5)	114.3 (4.50)	R29	73 (2.87)	4	
	300	209.5 (8.25)	168.1 (6.62)	29 (1.14)	29 (1.14)	36.9 (1.45)	1.6 (0.06)	22 (0.87)	127 (5)	123.8 (4.87)	R31	73 (2.87)	8	
	600	209.5 (8.25)	168.1 (6.62)	38.7 (1.52)	38.7 (1.52)	40.2 (1.58)	6.4 (0.25)	22 (0.87)	127 (5)	123.8 (4.87)	R31	73 (2.87)	8	
4"	150	228.6 (9)	190.5 (7.5)	24.4 (0.96)	24.4 (0.96)	30.7 (1.21)	1.6 (0.06)	19 (0.75)	158 (6.22)	149.2 (5.87)	R36	96 (3.78)	8	
	300	254 (10)	200 (7.87)	32.2 (1.27)	32.2 (1.27)	40.2 (1.58)	1.6 (0.06)	22 (0.87)	158 (6.22)	149.2 (5.87)	R37	96 (3.78)	8	
	600	273 (10.75)	215.9 (8.5)	45 (1.77)	45 (1.77)	46.5 (1.83)	6.4 (0.25)	25 (1)	158 (6.22)	149.2 (5.87)	R37	96 (3.78)	8	
EN 1092-1 DIMENSIONS														
DN	PN	A	B	C (RF)	C1 (FF)	D	E	F (RF)			G	HOLES		
DN40	10/40	150 (5.9)	110 (4.33)	20 (0.78)	20 (0.78)	3 (0.12)	18 (0.71)	88 (3.46)			40 (1.57)	4		
DN50	10/40	165 (6.5)	125 (4.92)	20 (0.78)	22 (0.86)	3 (0.12)	18 (0.71)	102 (4.01)			48 (1.89)	4		
DN80	10/40	200 (7.87)	160 (6.3)	24 (0.95)	24 (0.94)	3 (0.12)	18 (0.71)	138 (5.43)			73 (2.87)	8		
DN100	10/16	220 (8.67)	180 (7.08)	20 (0.78)		3 (0.12)	18 (0.71)	158 (6.22)			96 (3.78)	8		
	25/40	235 (9.25)	190 (7.5)	24 (0.95)		3 (0.12)	22 (0.87)	162 (6.38)			96 (3.78)	8		
JIS B 2202 DIMENSIONS														
DN	CLASS	A	B	C	D	E	F (RF)			G	HOLES			
40A	20K	140 (5.5)	105 (4.13)	26 (1.02)	2 (0.08)	19 (0.75)	81 (3.2)			40 (1.57)	4			
50A	10K	155 (6.1)	120 (4.72)	26 (1.02)	2 (0.08)	19 (0.75)	96 (3.78)			48 (1.89)	4			
	40K	165 (6.5)	130 (5.12)	26 (1.02)	2 (0.08)	19 (0.75)	105 (4.13)			48 (1.89)	8			
80A	10K	185 (7.28)	150 (5.9)	26 (1.02)	2 (0.08)	19 (0.75)	126 (4.96)			73 (2.87)	8			
	20K	200 (7.87)	160 (6.3)	26 (1.02)	2 (0.08)	19 (0.75)	132 (5.2)			73 (2.87)	8			
100A	10K	210 (8.27)	175 (6.89)	26 (1.02)	2 (0.08)	19 (0.75)	151 (5.95)			96 (3.78)	8			

LD300L - Flanged Pressure Transmitter with Slip-on Flange

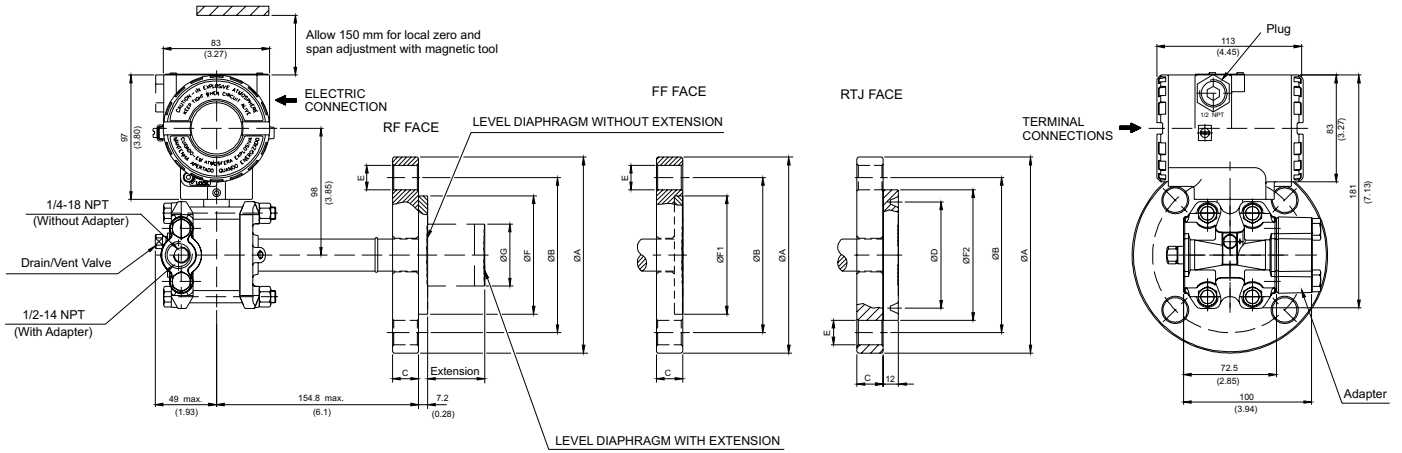

ANSI-B 16.5 DIMENSIONS											
DN	CLASS	A	B	C	D	E	F (RF)	F1 (FF)	F2 (RTJ)	G	# HOLES
1"	150	108 (4.25)	79.4 (3.16)	14.3 (0.56)	-	16 (0.63)	50.8 (2)	50.8 (2)	-	-	4
	300/600	124 (4.88)	88.9 (3.5)	17.5 (0.69)	-	19 (0.75)	50.8 (2)	50.8 (2)	-	-	4
1 1/2"	150	127 (5)	98.4 (3.87)	17.5 (0.69)	-	16 (0.63)	73 (2.87)	73 (2.87)	-	40 (1.57)	4
	300/600	156 (6.14)	114.3 (4.5)	22.2 (0.87)	-	22 (0.87)	73 (2.87)	73 (2.87)	-	40 (1.57)	4
2"	150	152.4 (6)	120.7 (4.75)	17.5 (0.69)	82.6 (3.25)	19 (0.75)	92 (3.62)	92 (3.62)	101.6 (4.00)	48 (1.89)	4
	300	165.1 (6.5)	127 (5)	20.7 (0.8)	82.6 (3.25)	19 (0.75)	92 (3.62)	92 (3.62)	107.9 (4.25)	48 (1.89)	8
	600	165.1 (6.5)	127 (5)	25.4 (1)	82.6 (3.25)	19 (0.75)	92 (3.62)	92 (3.62)	107.9 (4.25)	48 (1.89)	8
3"	150	190.5 (7.5)	152.4 (6)	22.3 (0.87)	114.3 (4.50)	19 (0.75)	127 (5)	127 (5)	133.4 (5.25)	73 (2.87)	4
	300	209.5 (8.25)	168.1 (6.62)	27 (1.06)	123.8 (4.87)	22 (0.87)	127 (5)	127 (5)	146.1 (5.75)	73 (2.87)	8
	600	209.5 (8.25)	168.1 (6.62)	31.8 (1.25)	123.8 (4.87)	22 (0.87)	127 (5)	127 (5)	146.1 (5.75)	73 (2.87)	8
4"	150	228.6 (9)	190.5 (7.5)	22.3 (0.87)	149.2 (5.87)	19 (0.75)	158 (6.22)	158 (6.22)	171.5 (6.75)	89 (3.5)	8
	300	254 (10)	200 (7.87)	30.2 (1.18)	149.2 (5.87)	22 (0.87)	158 (6.22)	158 (6.22)	174.6 (6.87)	89 (3.5)	8
	600	273 (10.75)	215.9 (8.5)	38.1 (1.5)	149.2 (5.87)	25 (1)	158 (6.22)	158 (6.22)	174.6 (6.87)	89 (3.5)	8

EN 1092-1 / DIN2501 DIMENSIONS - RF/ FF								
DN	PN	A	B	C	E	F	G	# HOLES
25	10/40	115 (4.53)	85 (3.35)	18 (0.71)	14 (0.55)	68 (2.68)	-	4
40	10/40	150 (5.91)	110 (4.33)	18 (0.71)	18 (0.71)	88 (3.46)	73 (2.87)	4
50	10/40	165 (6.50)	125 (4.92)	20 (0.78)	18 (0.71)	102 (4.01)	48 (1.89)	4
80	10/40	200 (7.87)	160 (6.30)	24 (0.95)	18 (0.71)	138 (5.43)	73 (2.87)	8
100	10/16	220 (8.67)	180 (7.08)	20 (0.78)	18 (0.71)	158 (6.22)	89 (3.5)	8
	25/40	235 (9.25)	190 (7.50)	24 (0.95)	22 (0.87)	162 (6.38)	89 (3.5)	8

NOTES:
 -EXTENSION LENGTH IN mm(in): 0, 50 (1.96), 100 (3.93), 150(5.9) or 200 (7.87)
 -FOR 1" AND DN25 THE EXTENSION LENGTH IS 0 mm
 -DIMENSIONS IN mm(in)

LD300L - Flanged Pressure Transmitter with Housing

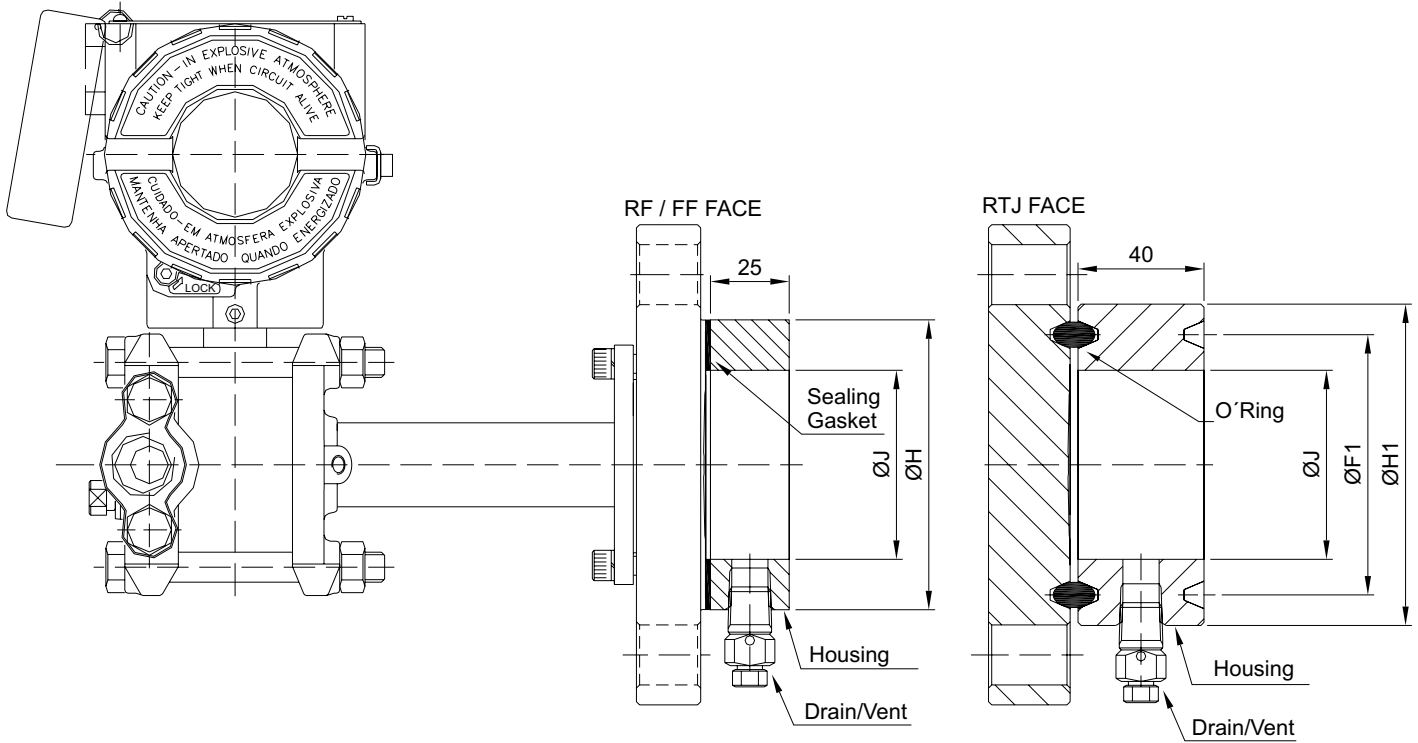

DIMENSIONS IN mm (")

ANSI-B 16.5 DIMENSIONS			
DN	CLASS	H	J
1.1/2"	ALL	73,2 (2,88)	48 (1,89)
2"		91,9 (3,62)	60 (2,36)
3"		127 (5,00)	89 (3,50)
4"		158 (6,22)	115 (4,53)
DIN EN1092-1/ DIN2501/2526 FORM D DIMENSIONS			
DN	PN	H	J
40	ALL	88 (3,46)	48 (1,89)
50		102 (4,02)	60 (2,36)
80		138 (5,43)	89 (3,50)
100		158 (6,22)	115 (4,53)
JIS B 2202 DIMENSIONS			
DN	CLASS	H	J
40A	20K	81 (3,19)	48 (1,89)
50A	10K	96 (3,78)	60 (1,36)
	40K	105 (4,13)	60 (1,36)
80A	10K	126 (4,96)	89 (3,50)
	20K	132 (5,20)	89 (3,50)
100A	10K	151 (5,94)	115 (4,53)

DIMENSIONS IN mm (")

ANSI-B 16.5 DIMENSIONS - RTJ FACE					
DN	CLASS	F1	O'RING	H1	J
1.1/2"	150	65,1 (2,56)	R19	82,5 (3,25)	48 (1,89)
	300	68,3 (2,69)	R20	90,5 (3,56)	48 (1,89)
	600	68,3 (2,69)	R20	90,5 (3,56)	48 (1,89)
	1500	68,3 (2,69)	R20	92 (3,62)	48 (1,89)
	2500	82,6 (3,25)	R23	114 (4,50)	48 (1,89)
2"	150	82,6 (3,25)	R22	102 (4,00)	60 (2,36)
	300	82,6 (3,25)	R23	108 (4,25)	60 (2,36)
	600	82,6 (3,25)	R23	108 (4,25)	60 (2,36)
	1500	95,3 (3,75)	R24	124 (4,88)	60 (2,36)
	2500	101,6 (4,00)	R26	133 (5,25)	60 (2,36)
3"	150	114,3 (4,50)	R29	133 (5,25)	89 (3,50)
	300	123,8 (4,87)	R31	146 (5,75)	89 (3,50)
	600	123,8 (4,87)	R31	146 (5,75)	89 (3,50)
4"	150	149,2 (5,87)	R36	171 (6,75)	115 (4,53)
	300	149,2 (5,87)	R37	175 (6,88)	115 (4,53)
	600	149,2 (5,87)	R37	175 (6,88)	115 (4,53)

LD300S - Sanitary Transmitter with Extension

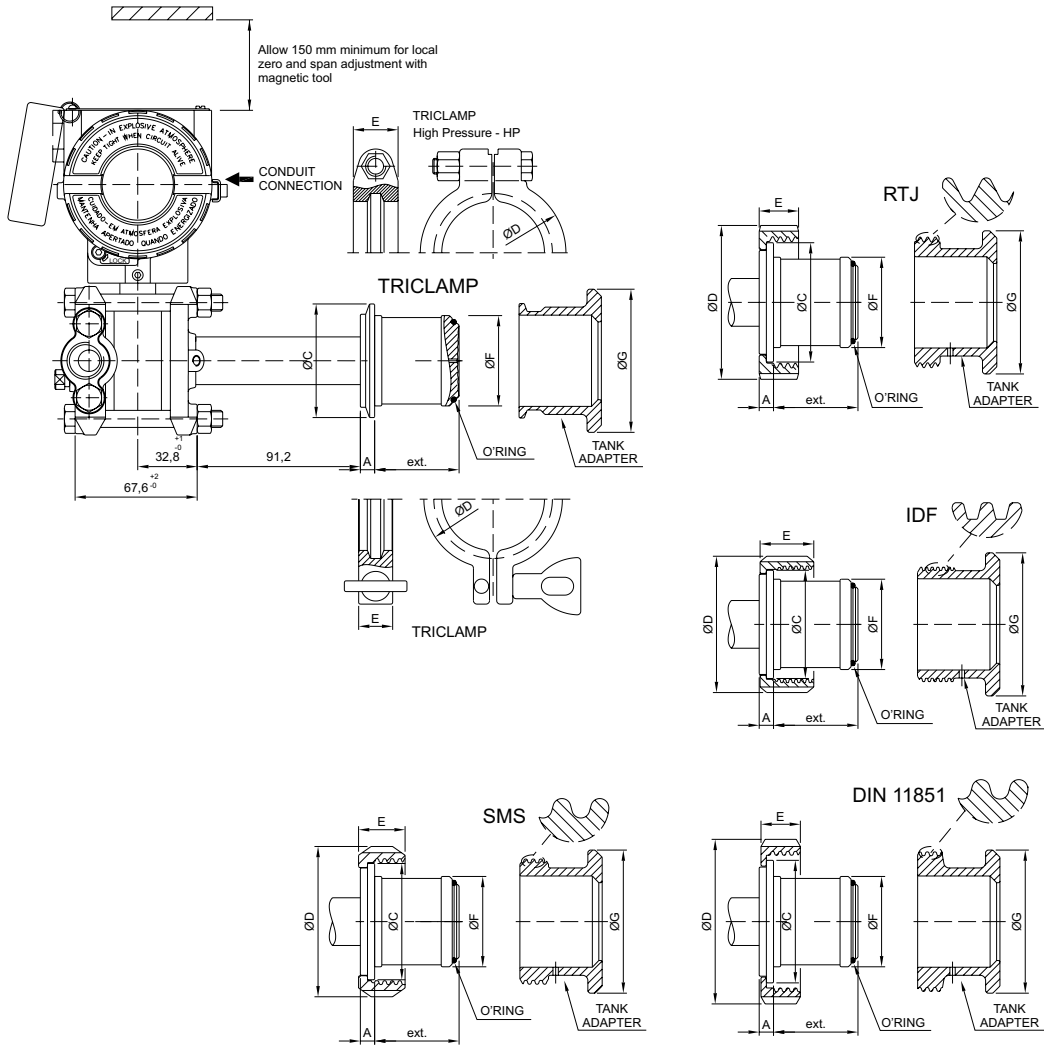

LD300S							
CONNECTION WITH EXTENSION	Dimensions in mm (")						
	A	ØC	ØD	E	ØF	ØG	EXT.
Tri-Clamp DN50	8 (0.315)	63.5 (2.5)	76.5 (3.01)	18 (0.71)	50.5 (1.99)	80 (3.15)	48 (1.89)
Tri-Clamp DN50 HP	8 (0.315)	63.5 (2.5)	81 (3.19)	25 (0.98)	50.5 (1.99)	80 (3.15)	48 (1.89)
Tri-Clamp - 2"	8 (0.315)	63.5 (2.5)	76.5 (3.01)	18 (0.71)	50.5 (1.99)	80 (3.15)	48 (1.89)
Tri-Clamp - 2" HP	8 (0.315)	63.5 (2.5)	81 (3.19)	25 (0.98)	50.5 (1.99)	80 (3.15)	48 (1.89)
Tri-Clamp - 3"	8 (0.315)	91 (3.58)	110 (4.33)	18 (0.71)	72.5 (2.85)	100 (3.94)	50 (1.96)
Tri-Clamp - 3" HP	8 (0.315)	91 (3.58)	115 (4.53)	25 (0.98)	72.5 (2.85)	100 (3.94)	50 (1.96)
Threaded DN25 - DIN 11851	6 (0.24)	47.5 (1.87)	63 (2.48)	21 (0.83)	43.2 (1.7)	80 (3.15)	26.3 (1.03)
Threaded DN40 - DIN 11851	8 (0.315)	56 (2.2)	78 (3.07)	21 (0.83)	50.5 (1.99)	80 (3.15)	48 (1.89)
Threaded DN50 - DIN 11851	8 (0.315)	68.5 (2.7)	92 (3.62)	22 (0.86)	50.5 (1.99)	80 (3.15)	48 (1.89)
Threaded DN80 - DIN 11851	8 (0.315)	100 (3.94)	127 (5)	29 (1.14)	72.5 (2.85)	100 (3.94)	50 (1.96)
Threaded SMS - 2"	8 (0.315)	65 (2.56)	84 (3.3)	26 (1.02)	50.5 (1.99)	80 (3.15)	48 (1.89)
Threaded SMS - 3"	8 (0.315)	93 (3.66)	113 (4.45)	32 (1.26)	72.5 (2.85)	100 (3.94)	50 (1.96)
Threaded RJT - 2"	8 (0.315)	66.7 (2.63)	86 (3.38)	22 (0.86)	50.5 (1.99)	80 (3.15)	48 (1.89)
Threaded RJT - 3"	8 (0.315)	92 (3.62)	112 (4.41)	22.2 (0.87)	72.5 (2.85)	100 (3.94)	50 (1.96)
Threaded IDF - 2"	8 (0.315)	60.5 (2.38)	76.2 (3)	30 (1.18)	50.5 (1.99)	80 (3.15)	48 (1.89)
Threaded IDF - 3"	8 (0.315)	87.5 (3.44)	101.6 (4)	30 (1.18)	72.5 (2.85)	100 (3.94)	50 (1.96)

LD300S - Sanitary Transmitter without Extension

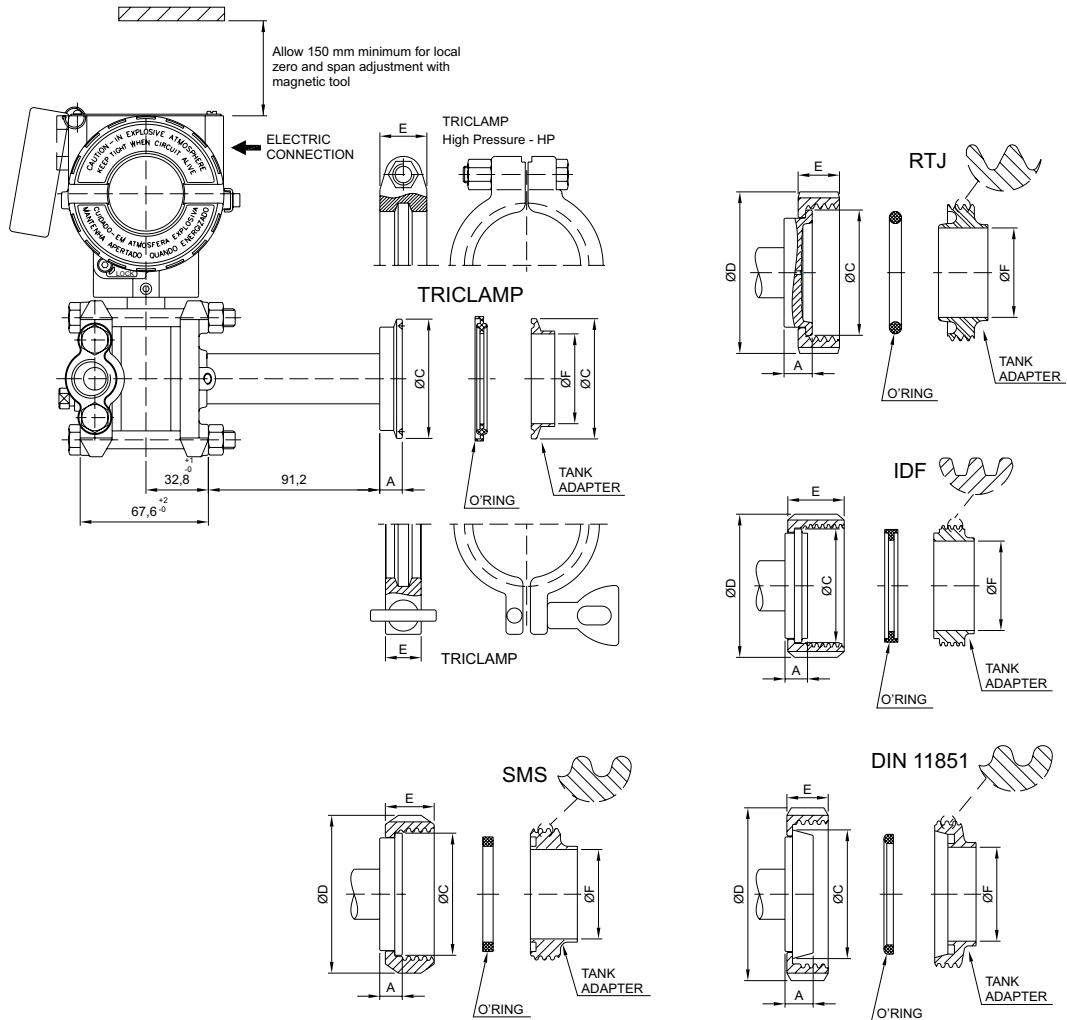

LD300S							
CONNECTION WITHOUT EXTENSION	Dimensions in mm (")						
	A	ØC	ØD	E	ØF	ØG	EXT.
Tri-Clamp DN50	8 (0.315)	63.5 (2.5)	76.5 (3.01)	18 (0.71)	47.5 (1.87)	---	---
Tri-Clamp - 1 1/2"	12 (0.47)	50 (1.96)	61 (2.4)	18 (0.71)	35 (1.38)	---	---
Tri-Clamp - 1 1/2" HP	12 (0.47)	50 (1.96)	66 (2.59)	25 (0.98)	35 (1.38)	---	---
Tri-Clamp - 2"	12 (0.47)	63.5 (2.5)	76.5 (3.01)	18 (0.71)	47.6 (1.87)	---	---
Tri-Clamp - 2" HP	12 (0.47)	63.5 (2.5)	81 (3.19)	25 (0.98)	47.6 (1.87)	---	---
Tri-Clamp - 3"	12 (0.47)	91 (3.58)	110 (4.33)	18 (0.71)	72 (2.83)	---	---
Tri-Clamp - 3" HP	12 (0.47)	91 (3.58)	115 (4.53)	25 (0.98)	72 (2.83)	---	---
Threaded DN40 - DIN 11851	13 (0.51)	56 (2.2)	78 (3.07)	21 (0.83)	38 (1.5)	---	---
Threaded DN50 - DIN 11851	15 (0.59)	68.5 (2.7)	92 (3.62)	22 (0.86)	50 (1.96)	---	---
Threaded DN80 - DIN 11851	16 (0.63)	100 (3.94)	127 (5)	29 (1.14)	81 (3.19)	---	---
Threaded SMS - 1 1/2"	12 (0.47)	55 (2.16)	74 (2.91)	25 (0.98)	35 (1.38)	---	---
Threaded SMS - 2"	12 (0.47)	65 (2.56)	84 (3.3)	26 (1.02)	48.6 (1.91)	---	---
Threaded SMS - 3"	12 (0.47)	93 (3.66)	113 (4.45)	32 (1.26)	73 (2.87)	---	---
Threaded RJT - 2"	15 (0.59)	66.7 (2.63)	86 (3.38)	22 (0.86)	47.6 (1.87)	---	---
Threaded RJT - 3"	15 (0.59)	92 (3.62)	112 (4.41)	22.2 (0.87)	73 (2.87)	---	---
Threaded IDF - 2"	12 (0.47)	60.5 (2.38)	76 (2.99)	30 (1.18)	47.6 (1.87)	---	---
Threaded IDF - 3"	12 (0.47)	87.5 (3.44)	101.6 (4)	30 (1.18)	73 (2.87)	---	---

smar

www.smar.com

Specifications and information are subject to change without notice.
Up-to-date address information is available on our website.

web: www.smar.com/contactus.asp

